

MODify Gondola Kit 03

MODify™ is a one-of-a-kind Modular Merchandising System that is made up of interchangeable fixtures and accessories that can be easily assembled, disassembled, and rearranged to create a variety of different display configurations. The MODify system incorporates SEG push-fit fabric graphics that enable you to brand, promote and merchandise with ease.

MODify Gondola Kit 03 features three frames (center, side, and header) that all include SEG push-fit printed graphics. With its rolling base, this display is versatile and can be placed almost anywhere. Enhance and MODify by incorporating optional shelves or hang bars to showcase merchandise.



We are continually improving and modifying our product range and reserve the right to vary the specifications without prior notice. All dimensions and weights quoted are approximate and we accept no responsibility for variance. E&OE. See Graphic Templates for graphic bleed specifications

features and benefits:

Base Kit includes:

- Frame, slatwall, shelf and base colors in kit are all the same, your choice of all white, black, or silver
- Heavy-duty aluminum frame, steel base
- Steel, slotted uprights
- Three frames: side, center, one header
- Center section holds 35.5"W x 57"H SEG push-fit fabric graphic, one on each side
- End cap includes a 37"W x 57"H SEG push-fit fabric graphic and black liner on inside
- Rolling base (casters included)
- Display is easy to assemble and install
- Lifetime hardware warranty against manufacturer defects

Optional Accessories Include:

- Towel bars.
- U bars
- Faceout bars
- Shelves

dimensions:

Hardware	Shipping
<p>Assembled unit:</p> <p>39"W x 61.5"H x 37.5"D 990.6mm(w) x 1562.1mm(h) x 952.5mm(d)</p> <p>Approximate Weight: 87 lbs / 39.4625 kg</p>	<p>Packing case(s): 1 Box</p> <p>Shipping dimensions: (62"L x 14"H x 24"D) 1574.8mm(l) x 355.6mm(h) x 609.6mm(d)</p> <p>Approximate shipping weight: 145 lbs / 65.7709 kg</p>

Graphics

Graphic material: Dye-sublimated fabric

See graphic templates for graphic sizes.

Refer to related graphic templates for more information Visit:

<https://www.theexhibitorshandbook.com/downloads/download-graphic-templates>
or click here

additional information:

Powder coat color options:

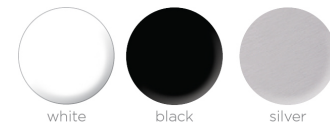

Wood laminate color options:

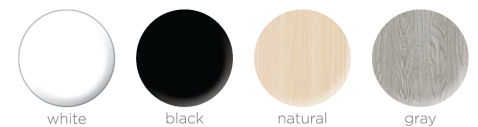

MODify Accessories

All Accessories available in white, black, or silver

Slotwall Accessories

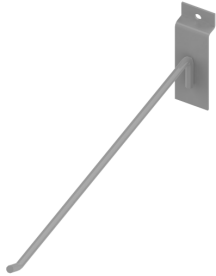

MFY-SLT-HK
4", 6", 8", 10" & 12"

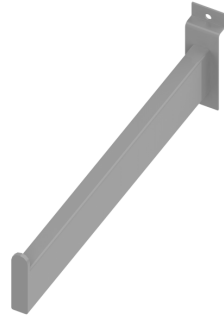

MFY-SLT-FC
6", 8", 10" & 12"

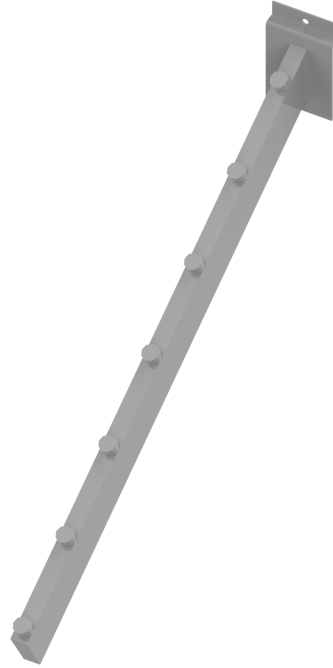

MFY-SLT-WTR-16-7

U-Bar Accessories

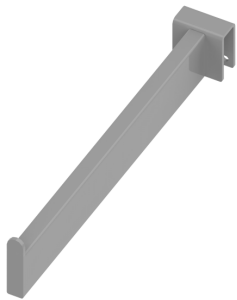

MFY-TWL-FC
6", 8" & 10"

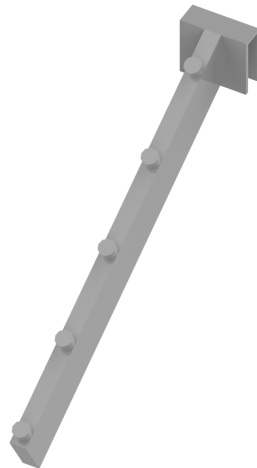

MFY-UBR-FC
6", 8" & 10"



MFY-CSTR-4-PK

Shelf and Hanger Bars

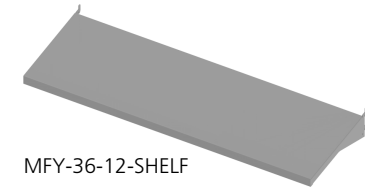

MFY-36-12-SHELF

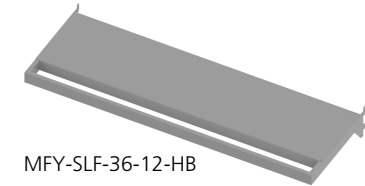

MFY-SLF-36-12-HB

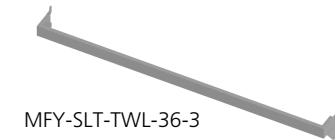

MFY-SLT-TWL-36-3

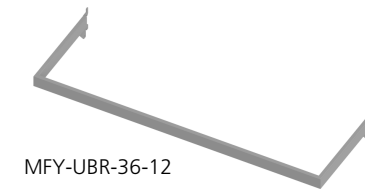

MFY-UBR-36-12

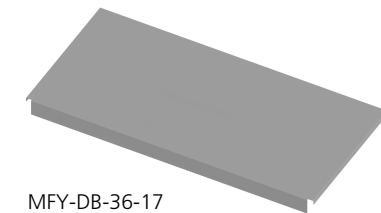

MFY-DB-36-17

Tools Required



MULTI HEX KEY
(INCLUDED)



PHILLIPS SCREW DRIVER
(NOT INCLUDED)



9/16" SOCKET WRENCH
(NOT INCLUDED)

How to Apply & Remove Graphics

Installation and removal of SEG graphics is easy!

Installation: Push the SEG bead into each corner of the frame (1-4) with your thumb, then push the SEG bead into the middle of the run (5-8) and work your way around the perimeter of the frame until all beading is pushed in properly; if necessary, go around the perimeter again to ensure beading is secure in the extrusion profile.

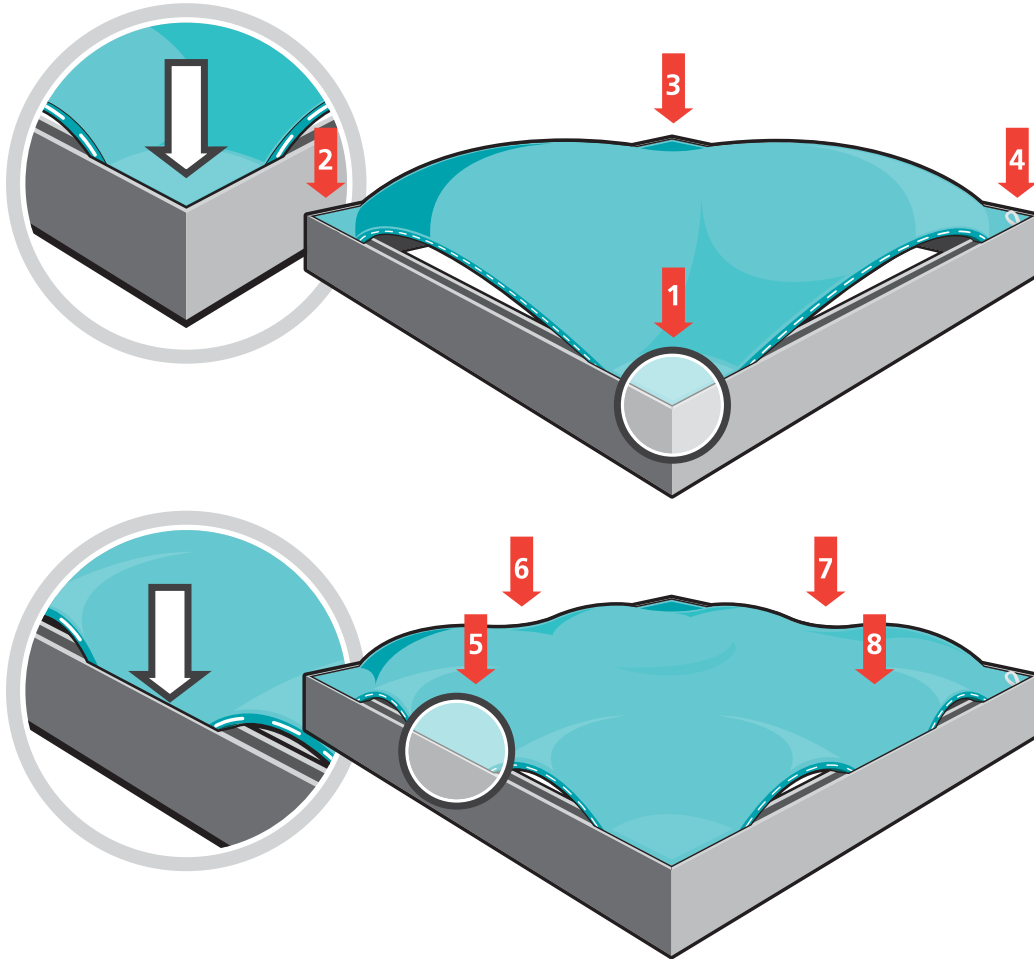





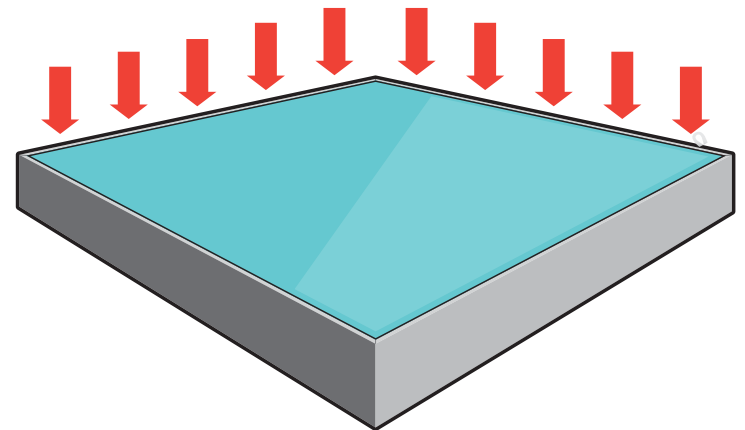

Note: Keep the set up area clean by using a drop cloth, washing hands before set-up or by wearing gloves.

Removal: Use the pull tab located on the graphic and gently pull the graphic from the frame, going around the perimeter.



Graphics Storage & Care

Graphics should be folded with the graphic facing inward and stored in a zip lock /sealable plastic bag. Spot clean by wiping with a damp white cloth. If washing is necessary, use a commercial size front-loading washing machine, gentle cycle with cool water. Line dry flat. Dry cleaning is NOT recommended to prevent shrinkage.

QTY	IMAGE	DESCRIPTION
2		3/8-16 x 2.5-3\" L bolt
1		1435MM (56.50in) OF 832 DOUBLE SIDED UPRIGHT OPEN EXTRUSION
1		1435MM (56.50in) OF 833) RIGHT UPRIGHT
2		2.5\" Caster, no brake and 5/16\" threaded post x 1.4\" length
1		947MM (37.28IN) RIGHT SUPPORT LEG
2		2.5\" Caster, with brake and 5/16\" threaded post x 1.4\" length.
1		947MM (37.28IN) LEFT SUPPORT LEG

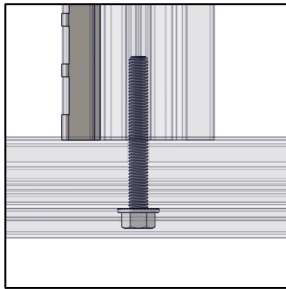
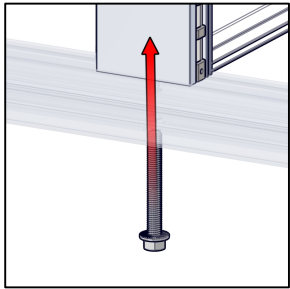

MFY-BOLT-375-16-2.5

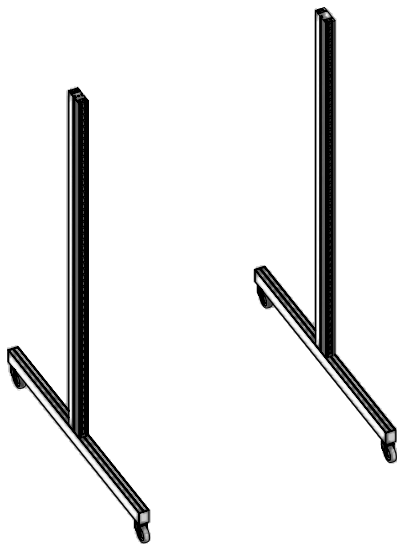

SETUP INSTRUCTIONS

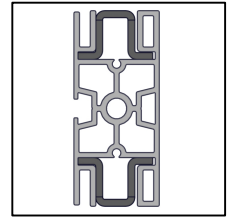

RIGHT UPRIGHT

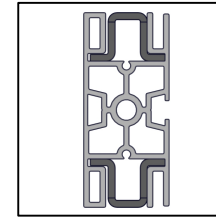

LEFT UPRIGHT

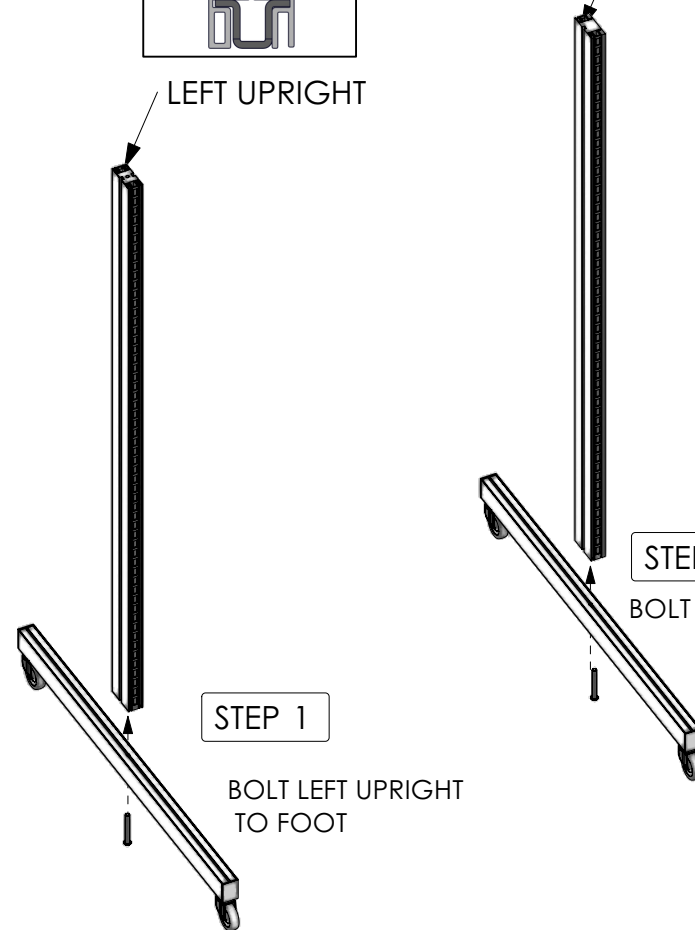

QTY	IMAGE	DESCRIPTION
2		883MM (34.7in) OF SINGLE SIDED SEG EXTRUSION -WITH CAM LOCKS BOTH ENDS
1		7MM SEG PLASTIC END CAP FOR 833 EXTRUSION
1		7MM SEG PLASTIC END CAP FOR 832 EXTRUSION

SETUP INSTRUCTIONS

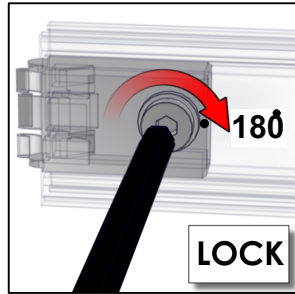

IMPORTANT! MAKE A HALF TURN
TO LOCK EXTRUSIONS

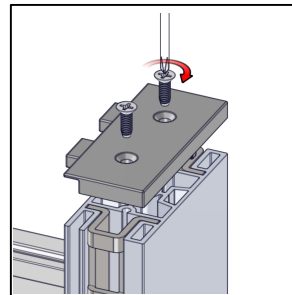
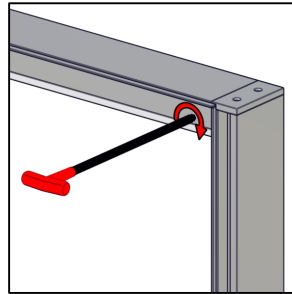

LOOSEN END CAP TO ATTACH
TOP CROSS BRACE

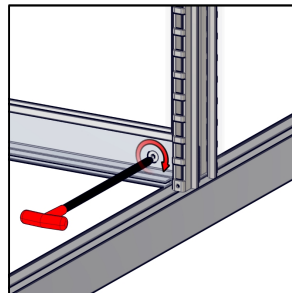

CROSS BRACE SITS
ON SUPPORT LEGS

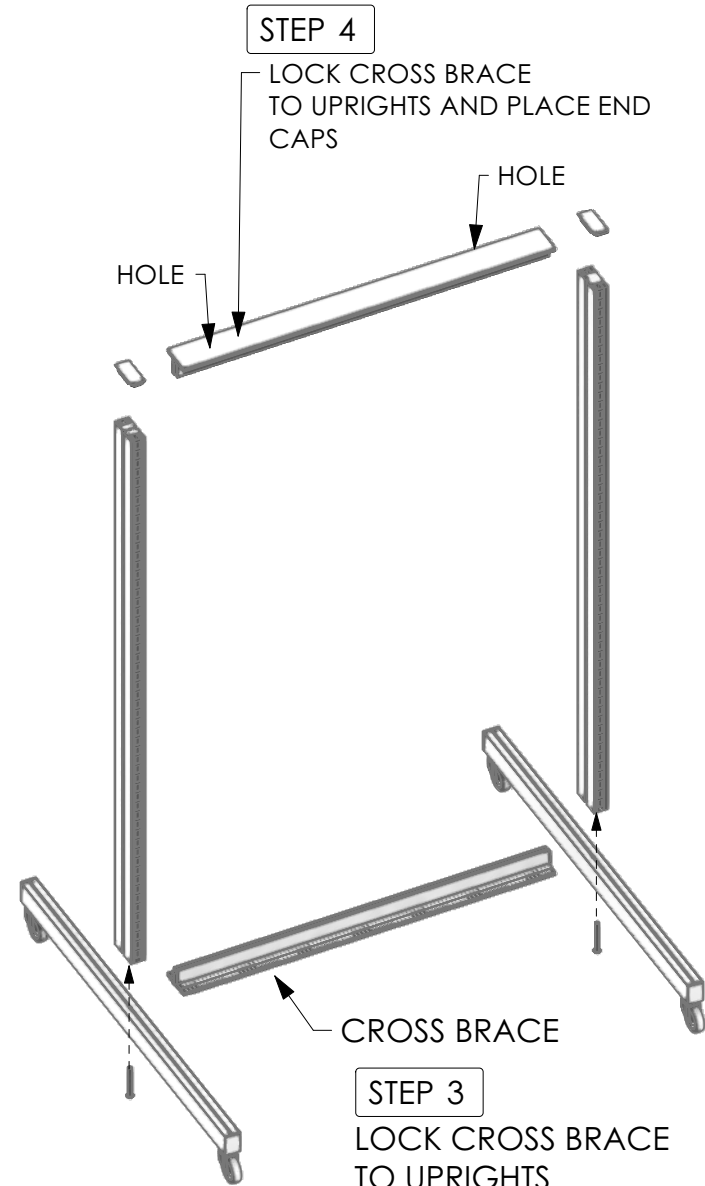
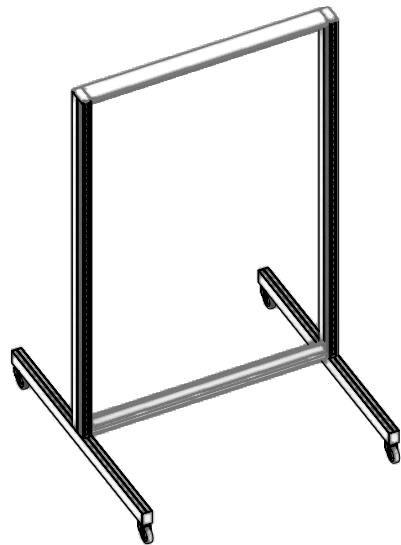

NOTE: BOTTOM CROSS BRACE SITS ON TOP INSIDE
EDGE OF LEFT AND RIGHT SUPPORT LEG

QTY	IMAGE	DESCRIPTION
2		(39.26 w X 60.59 h total size) 35.26 w X 56.59 h finish size, Dye-sub print on Eclipse Blockout Stretch, single sided, sewn with FCE-2 silicone beading around perimeter & pull tab in bottom right corner (WITH 1/4" NOTCH LEFT & RIGHT BOTTOM HORIZONTAL SIDE CORNERS)

SETUP INSTRUCTIONS

STEP 5

INSTALL GRAPHICS

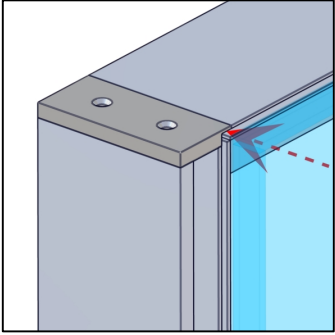



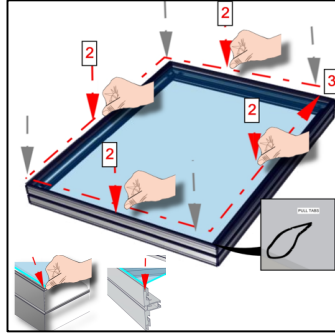

PRESS GRAPHIC INTO CORNERS

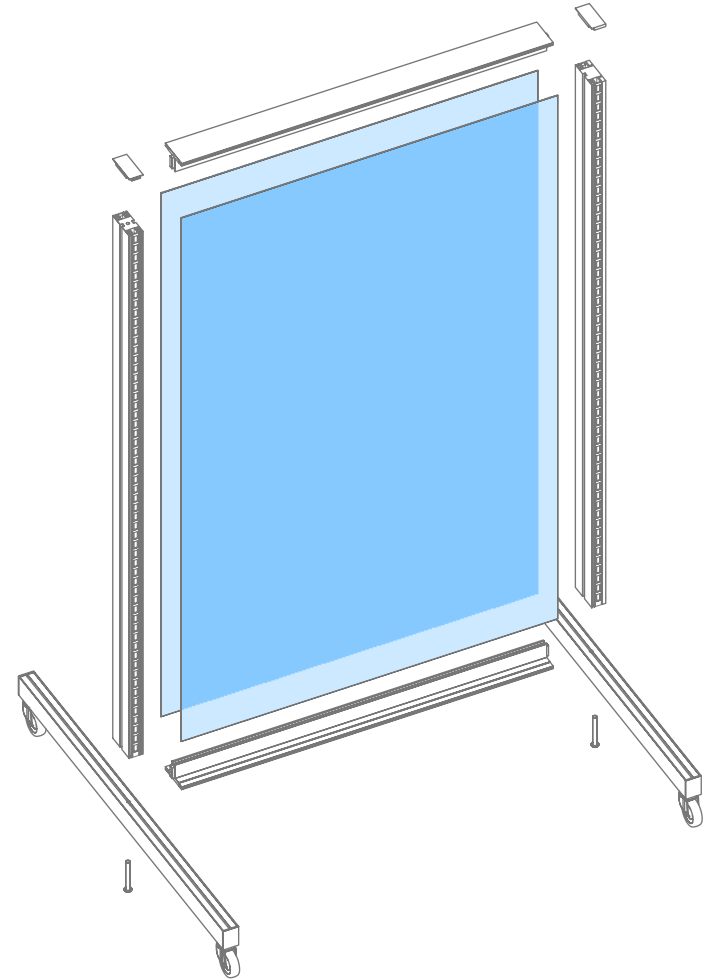
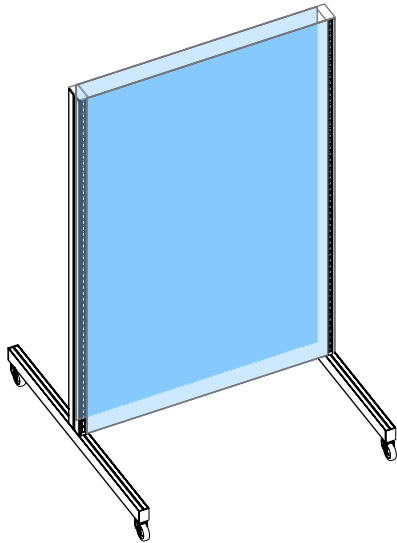

THEN PRESS ALONG THE PERIMETER EDGE



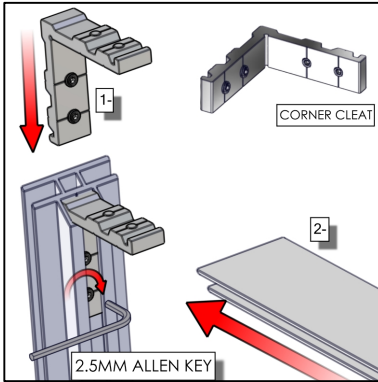

QTY	IMAGE	DESCRIPTION
1		943MM (37.13in) LENGTH OF WMFCD EXTRUSION 45 DEGREE MITER CUT BOTH ENDS WITH SIDE BRACKET
1		943MM (37.13in) LENGTH OF WMFCD EXTRUSION 45 DEGREE MITER CUT BOTH ENDS
2		1439MM (56.65in) LENGTH OF WMFCD EXTRUSION 45 DEGREE MITER CUT BOTH ENDS
4		SINGLE VECTOR CORNER CLEAT

STEP 6
ASSEMBLE FRAME

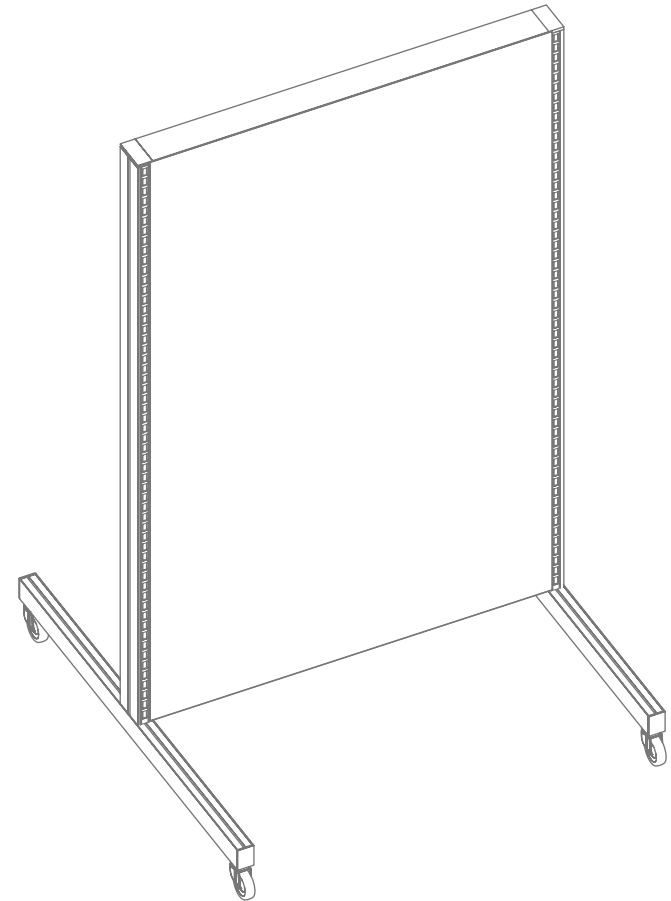
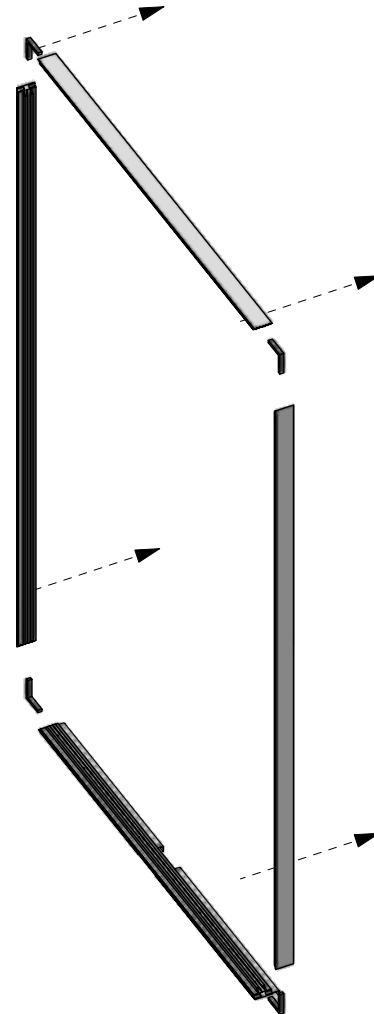
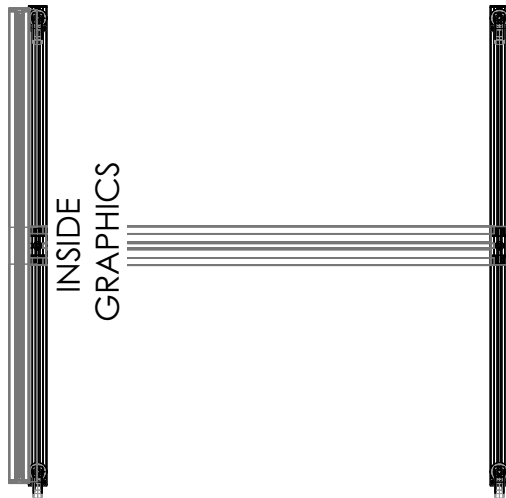

CORNER CLEAT



QTY	IMAGE	DESCRIPTION
1		(41.01 w X 60.52 h total size) 37.01 w X 56.52 h finish size, Unprinted 5oz. Black Soft Knit, sewn with silicone beading around perimeter & pull tab in bottom right corner



SETUP INSTRUCTIONS

STEP 7

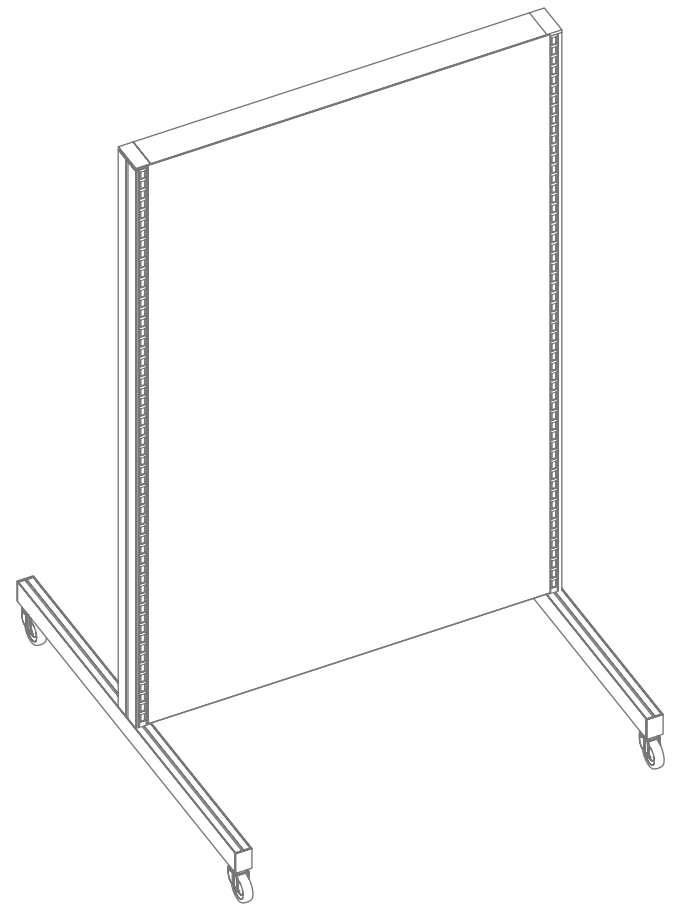
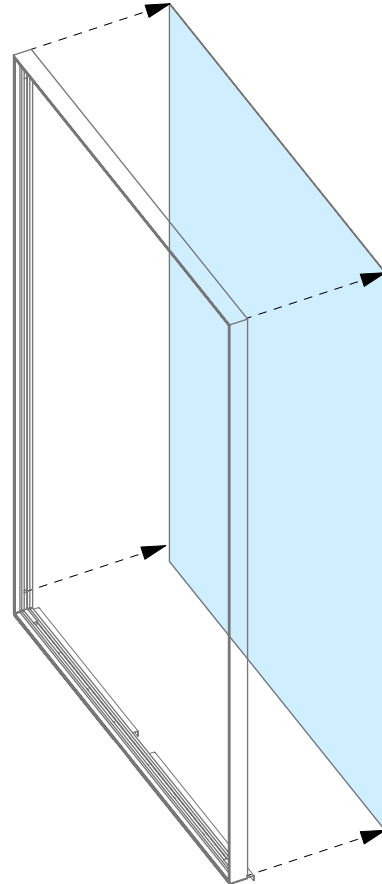
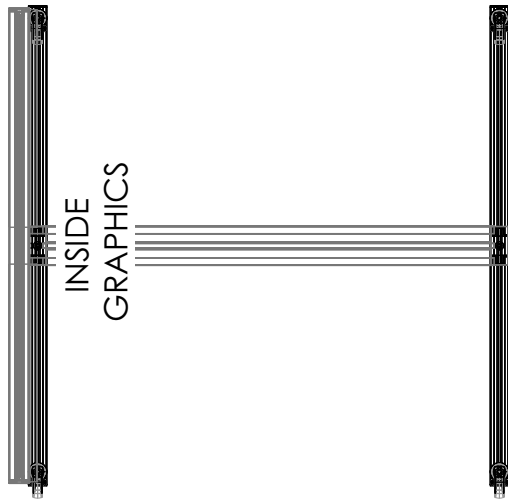
INSTALL
INSIDE
GRAPHICS



SETUP INSTRUCTIONS

QTY	IMAGE	DESCRIPTION
1		SIDE BRACKET
4		MFY-BOLT-8-32-0.75
1		(41.01 w X 60.52 h total size) 37.01 w X 56.52 h finish size, Dye-sub print on Eclipse Blockout Stretch, single sided, sewn with FCE-2 silicone beading around perimeter & pull tab in bottom right corner

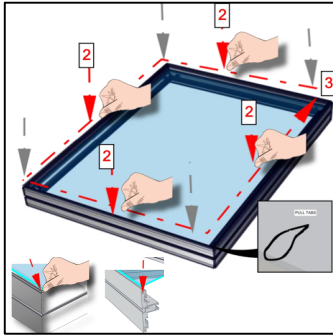

THEN PRESS ALONG THE PERIMETER EDGE

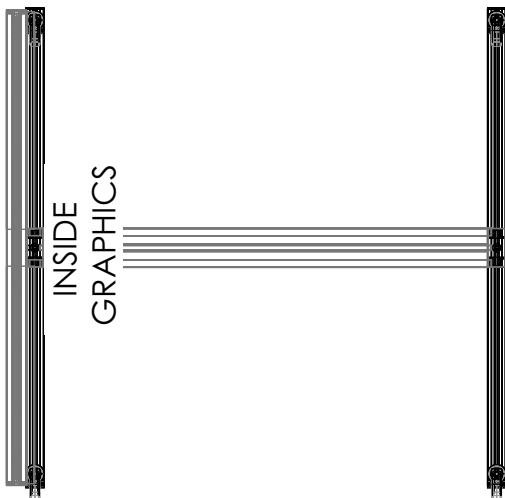

STEP 9 INSTALL OUTSIDE GRAPHIC

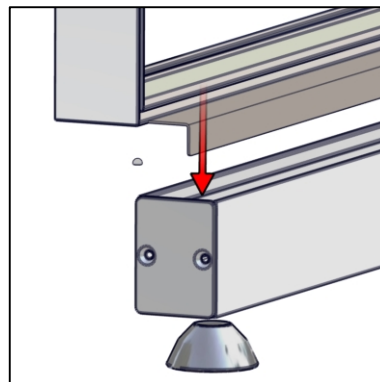
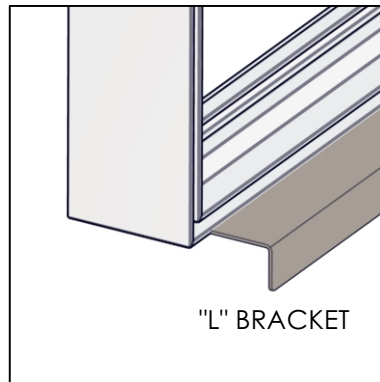
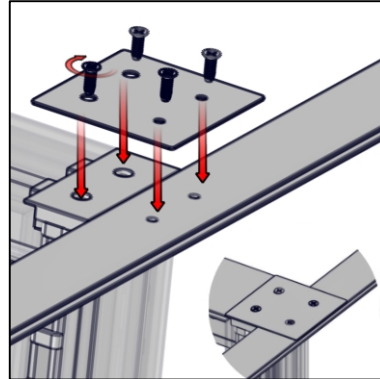



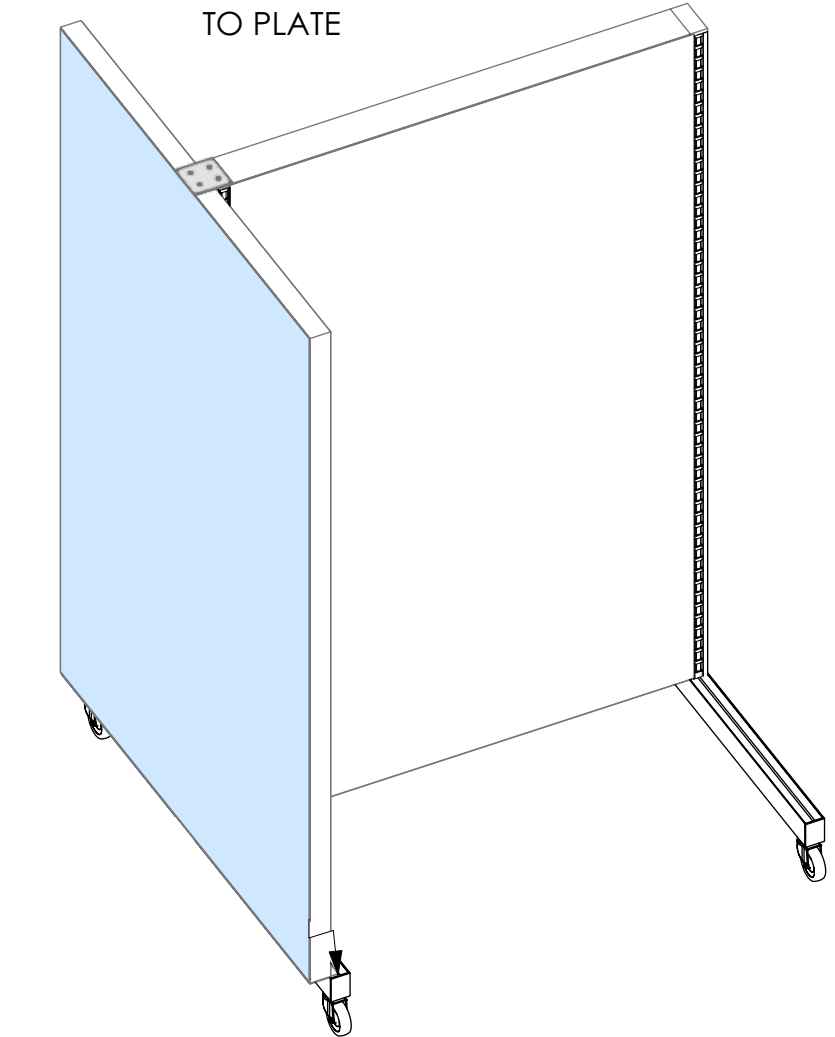

STEP 8

*FASTEN SCREWS TO PLATE



PLACE FRAME WITH "L" BRACKET ON GROOVE(FOOT)

QTY	IMAGE	DESCRIPTION
2		883MM (34.76in) LENGTH OF WMFCD EXTRUSION 45 DEGREE MITER CUT BOTH ENDS
4		SINGLE VECTOR CORNER CLEAT
2		305MM (12.01in) LENGTH OF WMFCD EXTRUSION 45 DEGREE MITER CUT BOTH ENDS
2		1/4"-20 x 13"L bolt

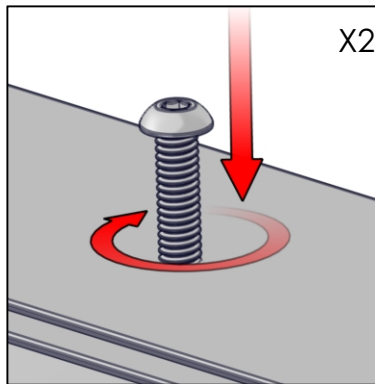

SETUP INSTRUCTIONS

STEP 11

ASSEMBLE FRAME
& BOLT TO TOP
OF THE CROSS BRACE

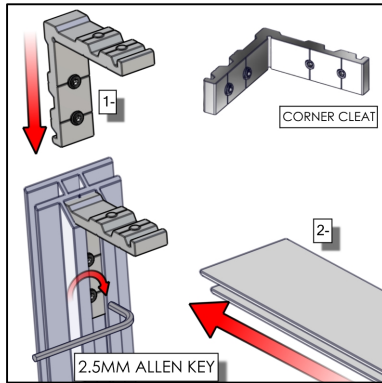



CORNER CLEAT

STEP 10

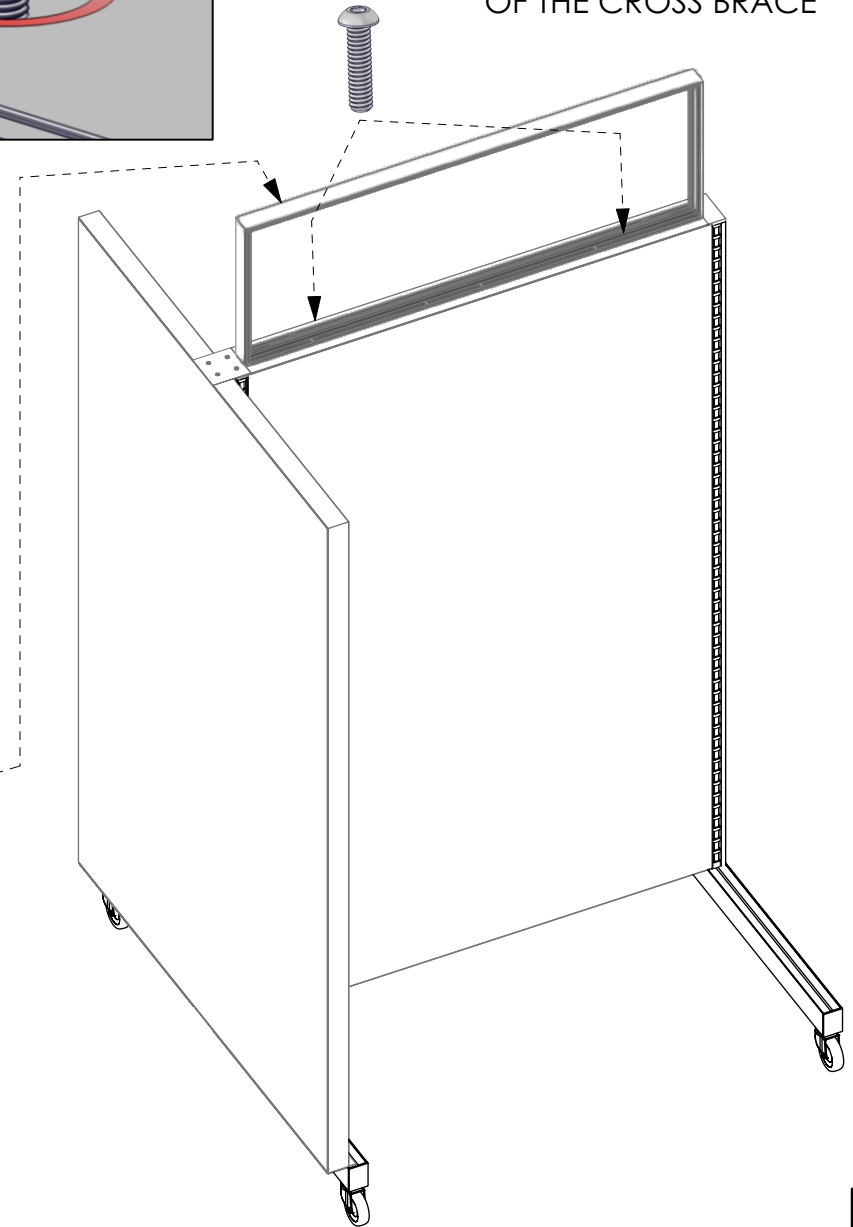
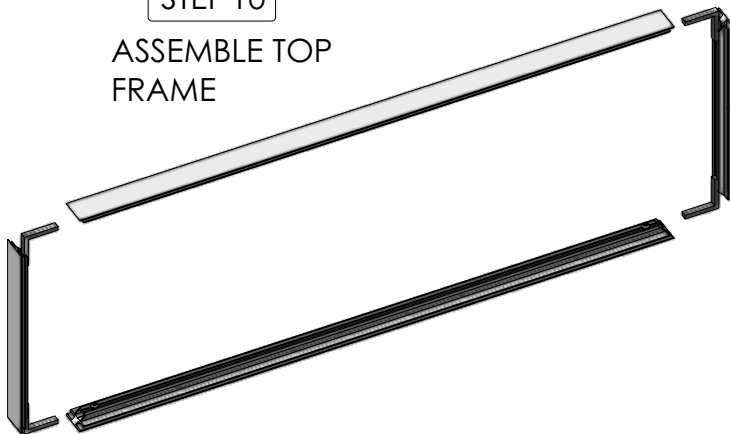
ASSEMBLE TOP
FRAME



QTY	IMAGE	DESCRIPTION
2		(38.65 w X 15.88 h total size) 34.65 w X 11.88 h finish size, Dye-sub print on Eclipse Blockout Stretch, single sided, sewn with FCE-2 silicone beading around perimeter & pull tab in bottom right corner
2		36in WIDE X 17.25in DEEP - DROP-IN BASE PAN

SETUP INSTRUCTIONS

STEP 12

ADD TOPPER GRAPHICS

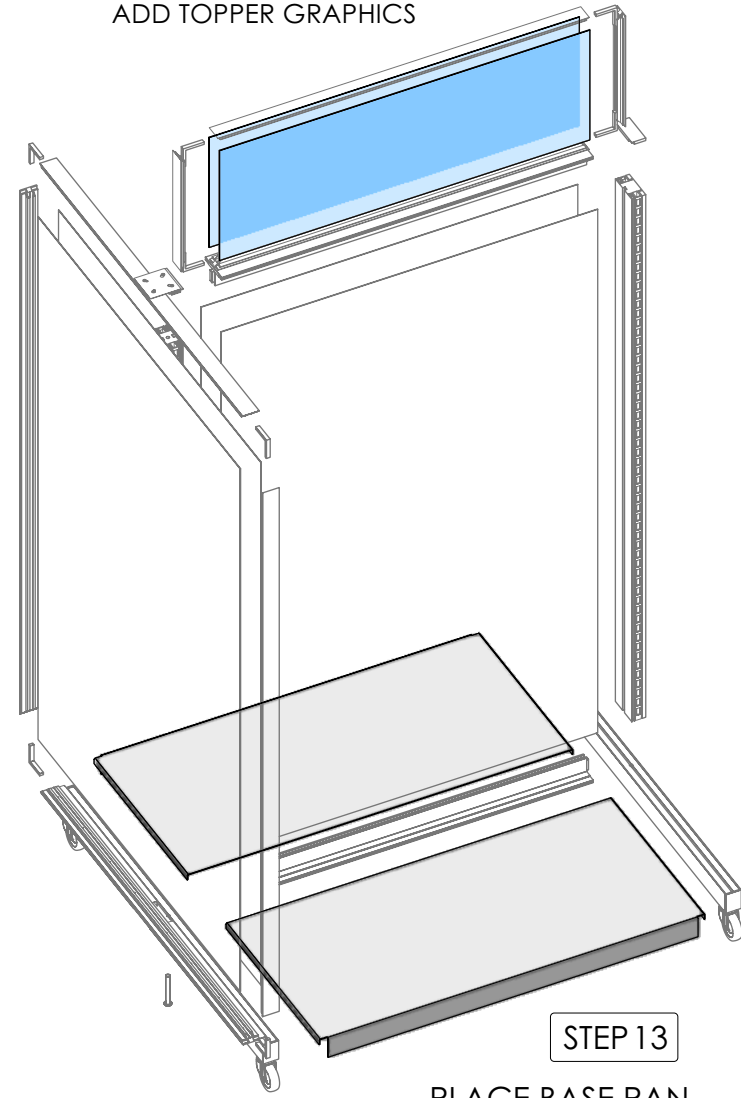

STEP 13

PLACE BASE PAN IN GROOVE(FOOT)

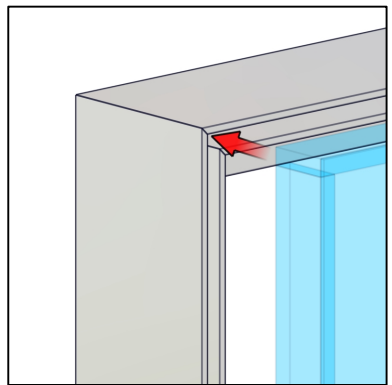

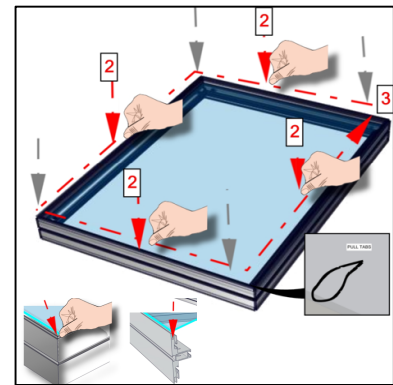

PRESS GRAPHIC INTO CORNERS









THEN PRESS ALONG THE PERIMETER EDGE

Kit Hardware BOM

ITEM	COMPONENTS	QTY	DESCRIPTION
	306-305-15-15	2	305MM (12.01in) LENGTH OF WMFCD EXTRUSION 45 DEGREE MITER CUT BOTH ENDS
	306-883-15-15	2	883MM (34.76in) LENGTH OF WMFCD EXTRUSION 45 DEGREE MITER CUT BOTH ENDS
	306-943-15-15	1	943MM (37.13in) LENGTH OF WMFCD EXTRUSION 45 DEGREE MITER CUT BOTH ENDS
	306-943-15-15	1	743MM (29.25in) LENGTH OF WMFCD EXTRUSION 45 DEGREE MITER CUT BOTH ENDS WITH SIDE BRACKET
	306-1439-15-15	2	1439MM (56.65in) LENGTH OF WMFCD EXTRUSION 45 DEGREE MITER CUT BOTH ENDS
	824-947	1	947MM (37.28IN) RIGHT SUPPORT LEG
	824-947	1	947MM (37.28IN) LEFT SUPPORT LEG
	832-1435	1	1435MM (56.50in) OF 832 DOUBLE SIDED UPRIGHT OPEN EXTRUSION
	832-EC	1	7MM SEG PLASTIC END CAP FOR 832 EXTRUSION
	833-1435	1	1435MM (56.50in) OF 833) RIGHT UPRIGHT
	833-EC	1	7MM SEG PLASTIC END CAP FOR 833 EXTRUSION
	835-883-01-01	2	883MM (34.76in) OF SINGLE SIDED SEG EXTRUSION -WITH CAM LOCKS BOTH ENDS
	MFY-BOLT-.25-20-1	2	1/4"-20 x 13"L bolt
	MFY-BOLT-8-32-0.75	4	MFY-BOLT-8-32-0.75
	MFY-BOLT-375-16-2.5	2	3/8-16 x 2.5-3"L bolt
	MFY-CSTR-L	2	2.5" Caster, with brake and 5/16" threaded post x 1.4" length.
	MFY-CSTR-NL	2	2.5" Caster, no brake and 5/16" threaded post x 1.4" length
	MFY-DB-36-17	2	36in WIDE X 17.25in DEEP - DROP-IN BASE PAN
	SIDE BRACRET	1	SIDE BRACKET
	VF-CC	8	SINGLE VECTOR CORNER CLEAT

Kit Graphics BOM

	MFY-GN-03-A-G	1	(41.01 w X 60.52 h total size) 37.01 w X 56.52 h finish size, Dye-sub print on Eclipse Blockout Stretch, single sided, sewn with FCE-2 silicone beading around perimeter & pull tab in bottom right corner
	MFY-GN-03-B-G	1	(41.01 w X 60.52 h total size) 37.01 w X 56.52 h finish size, Unprinted 5oz. Black Soft Knit, sewn with silicone beading around perimeter & pull tab in bottom right corner
	MFY-GN-03-C-G	1	(39.26 w X 60.59 h total size) 35.26 w X 56.59 h finish size, Dye-sub print on Eclipse Blockout Stretch, single sided, sewn with FCE-2 silicone beading around perimeter & pull tab in bottom right corner (WITH 1/4" NOTCH LEFT & RIGHT BOTTOM HORIZONTAL SIDE CORNERS)
	MFY-GN-03-D-G	1	(39.26 w X 60.59 h total size) 35.26 w X 56.59 h finish size, Dye-sub print on Eclipse Blockout Stretch, single sided, sewn with FCE-2 silicone beading around perimeter & pull tab in bottom right corner (WITH 1/4" NOTCH LEFT & RIGHT BOTTOM HORIZONTAL SIDE CORNERS)
	MFY-GN-03-E-G	1	(38.65 w X 15.88 h total size) 34.65 w X 11.88 h finish size, Dye-sub print on Eclipse Blockout Stretch, single sided, sewn with FCE-2 silicone beading around perimeter & pull tab in bottom right corner
	MFY-GN-03-F-G	1	(38.65 w X 15.88 h total size) 34.65 w X 11.88 h finish size, Dye-sub print on Eclipse Blockout Stretch, single sided, sewn with FCE-2 silicone beading around perimeter & pull tab in bottom right corner