

Charisma Inside-Out 3D Ceiling Cube - 120" x 120" with 12' cable

Identify the various Frame Assembly Components as shown below. First start by assembling corners. There are two (2) flat L-brackets per corner. All extrusion sections are numbered to identify which pieces go together, 1 with 1, 2 with 2, etc.

1. For the Bottom frame section, join the corner sections of the bottom portion of the frame using the L-brackets and screws.
2. For larger boxes, sides may be built in multiple sections. These sections end in a straight cut (NOT a 45° angle). Use the two (2) straight brackets to connect the two adjoining sections. The screws will be tightened from the inside of the frame. Sections can be identified with matching numbers.
3. Connect short joining wire between light strips at ALL corners.
4. Repeat step 1 to 3 for the Top section with eyebolts attached.

**PROFESSIONAL INSTALLATION
WITH MULTIPLE PEOPLE IS RECOMMENDED**

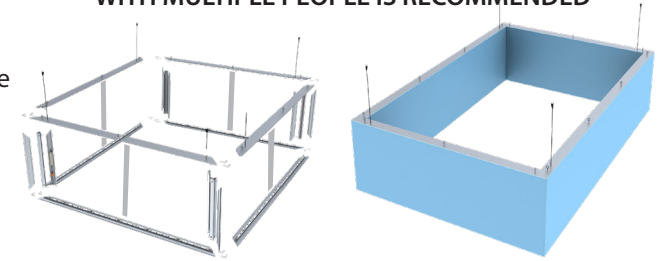

Frame Assembly Components

- Frame Top/Bottom
- Center Support
- Corner Support
- Outside Corner
- Inside Corner

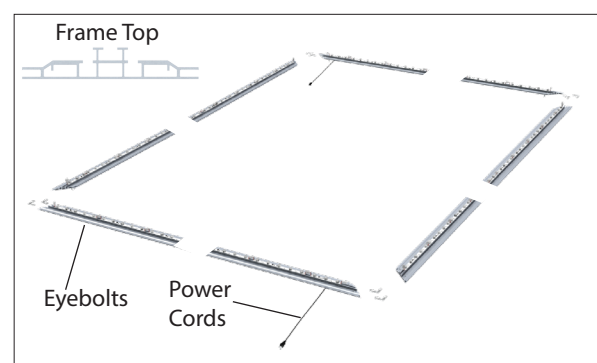
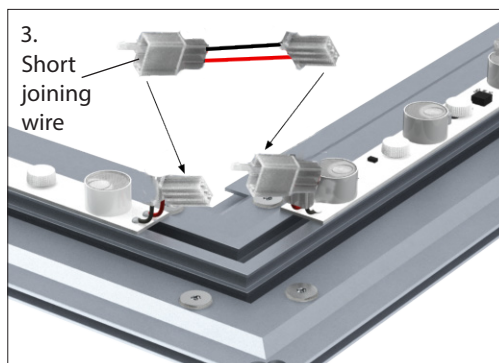
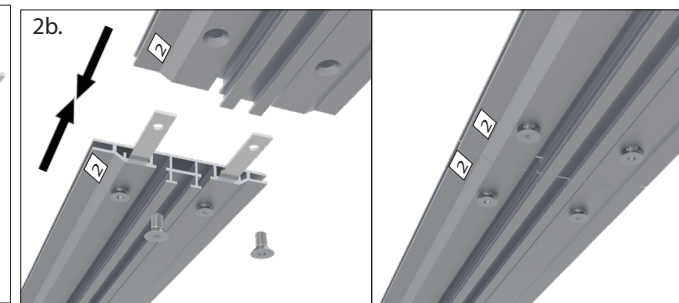
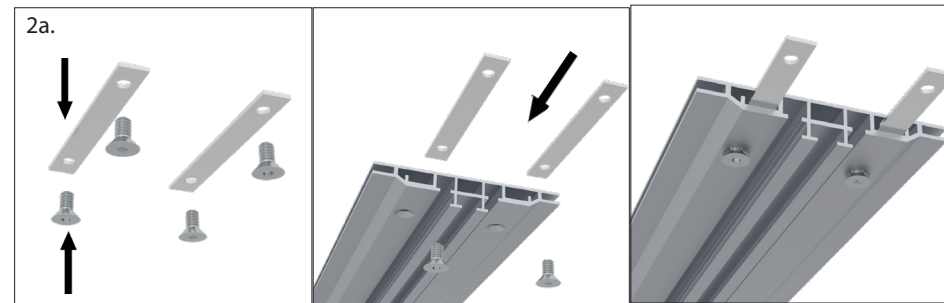
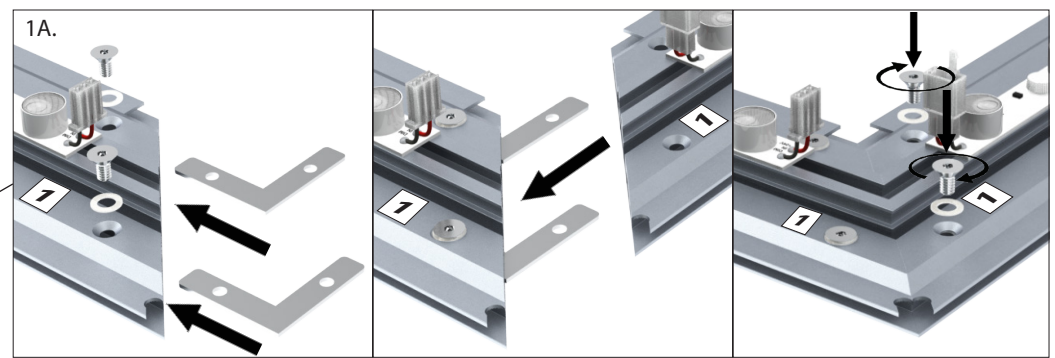
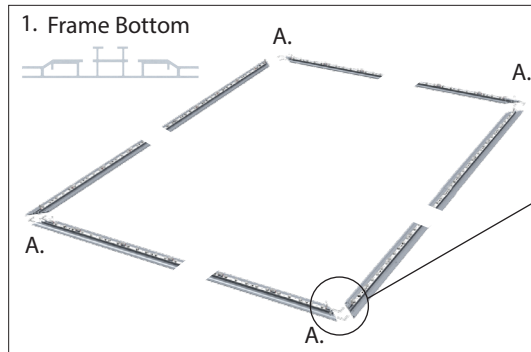

Charisma Inside-Out 3D Ceiling Cube - 120" x 120" with 12' cable

PROFESSIONAL INSTALLATION
WITH MULTIPLE PEOPLE IS RECOMMENDED

Identify the various Frame Assembly Components as shown below.

1. Connect the corner supports and fasten to bottom section using the hex key provided.
2. Place center support bar bracket into frame channel and use the Allen key to expand the bracket inside the channel to secure it in place.

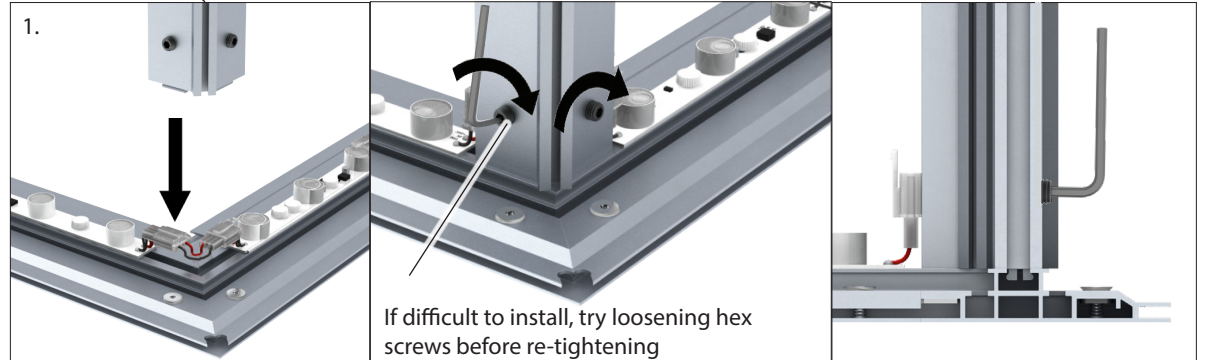
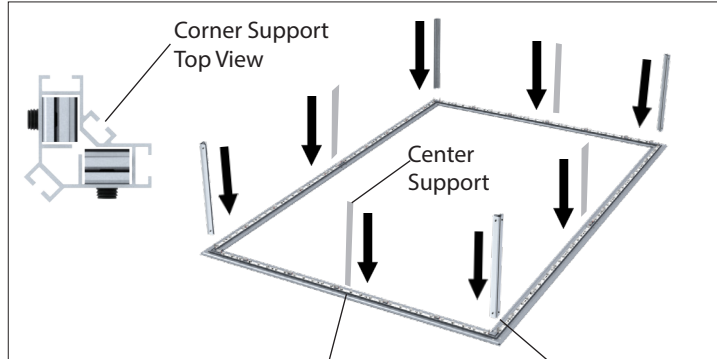
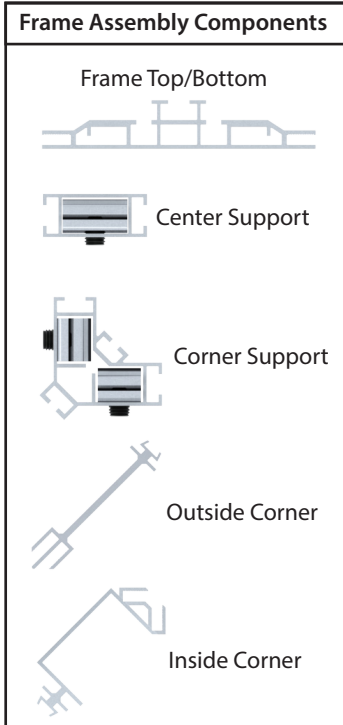
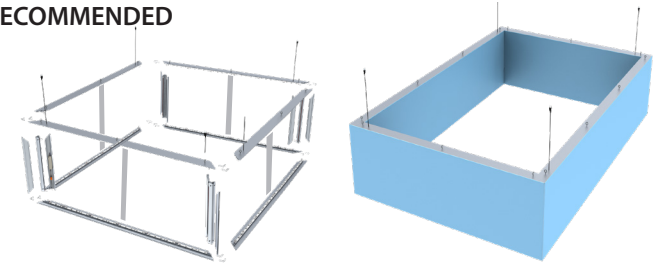

Charisma Inside-Out 3D Ceiling Cube - 120" x 120" with 12' cable

Inner and outer extrusions should fit into the notches of the top and bottom frame extrusions. If it doesn't fit, carefully jiggle the extrusions until they fit in. Don't force it.

1. Identify the outer corner extrusion, pictured below.
2. Slide outside corner extrusion down channel of upright section as shown below, slowly lowering it into place. The corner of the extrusion will sit into the notched space of the bottom frame corner. Do not force or drop into place.
3. Slide inside corner extrusion down channel of upright section as shown below, slowly lowering it into place. The corner of the extrusion will sit into the notched space of the bottom frame corner. Do not force or drop into place.

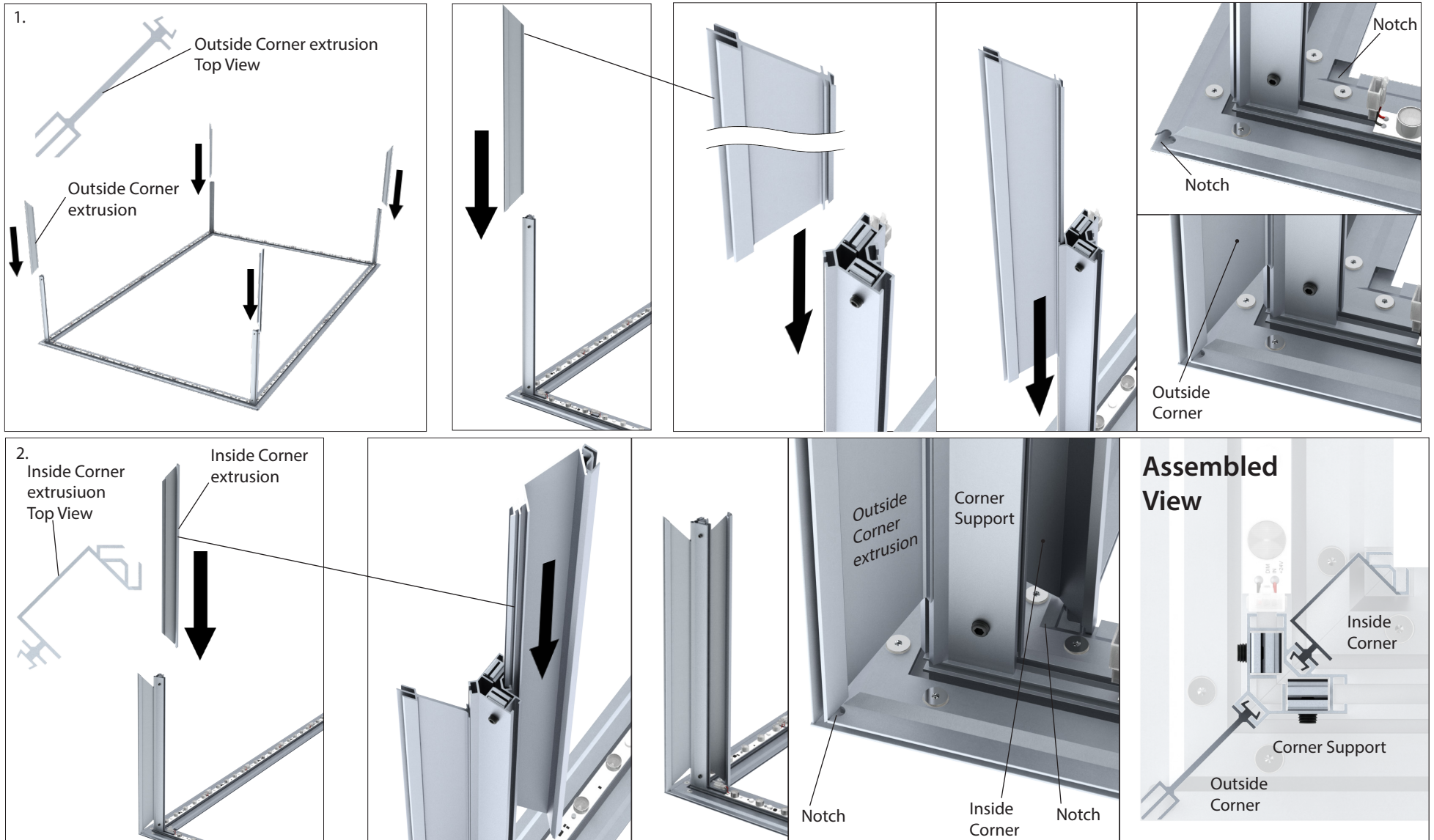

Charisma Inside-Out 3D Ceiling Cube - 120" x 120" with 12' cable

1. Attach the Top frame section to the uprights and fasten the screws using the hex key provided.
Corners of outside and inside extrusions will sit in the notches of the top of the frame.

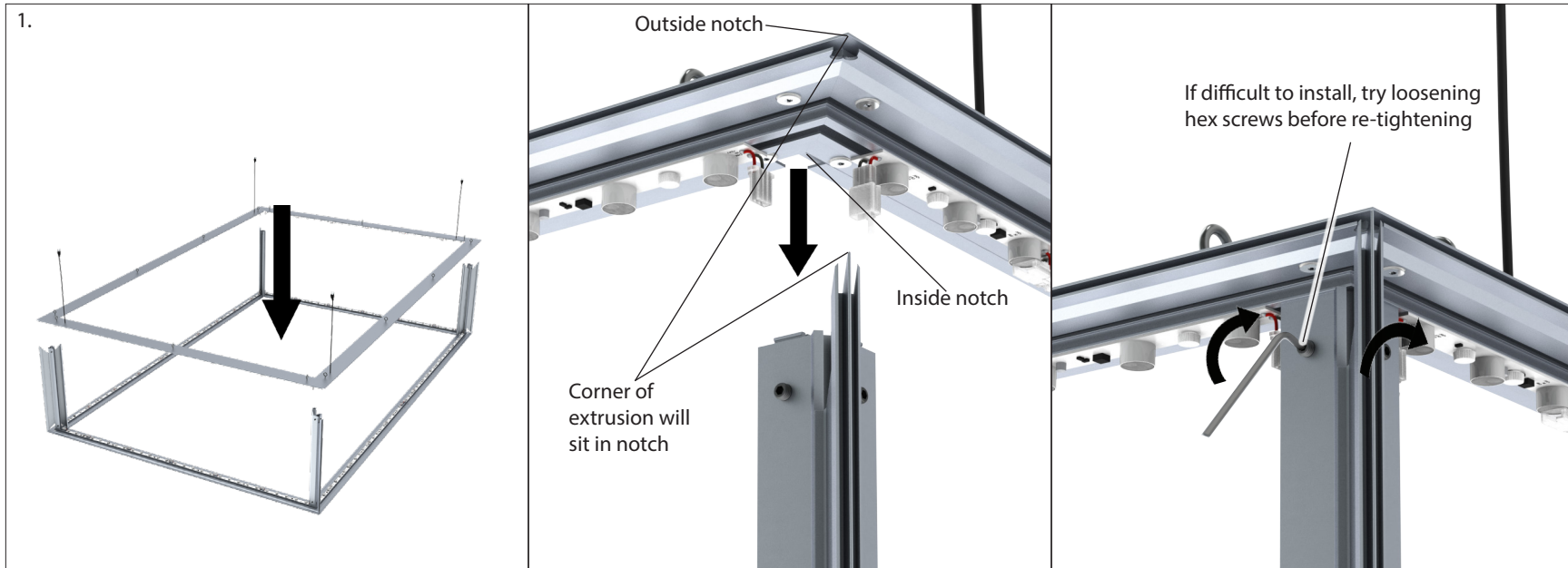

Charisma Inside-Out 3D Ceiling Cube - 120" x 120" with 12' cable

1. At each break in the extrusion, identify the orange or white electrical connector. Then connect the white female connectors to their matching male connectors and the orange female connector to their matching male connector. The connectors must fully "click" together.
2. It is normal for the last female white connector to be unconnected to anything else.
3. If there are multiple cables, connect those with matching colors (not shown).

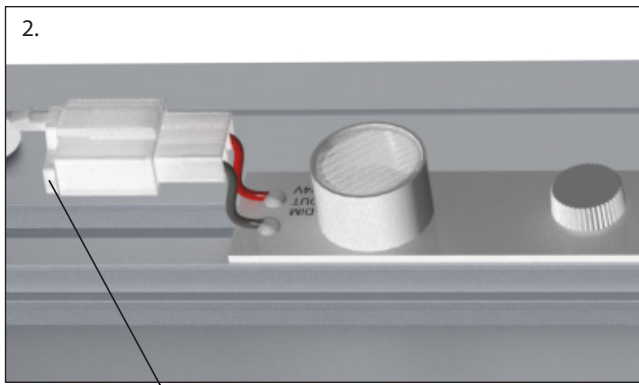
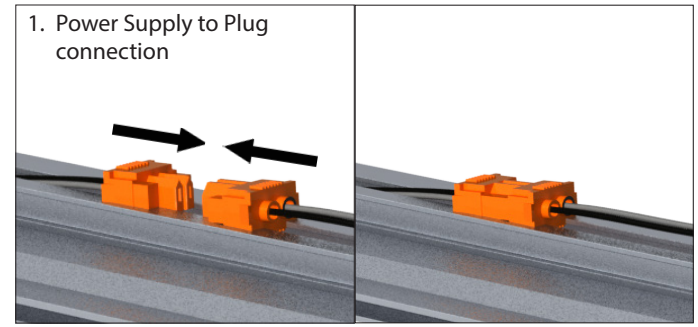
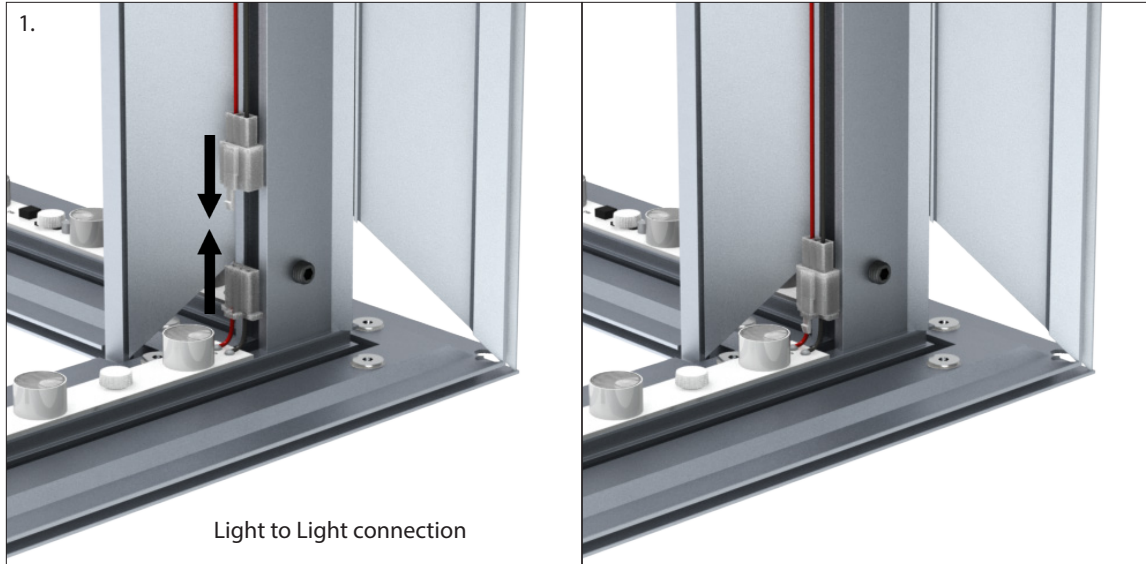

Unconnected last female connector is normal

Charisma Inside-Out 3D Ceiling Cube - 120" x 120" with 12' cable

Be sure to wear the gloves included before handling the graphics, to keep the backer and graphic clean. Follow the steps below to install the INSIDE face graphics FIRST, then proceed to installing the outside face graphics.

Outside face graphic is shown in the steps below for clarity.

1. To install the graphic, take the corner with the pull tag on it and press about 6"-10" of silicone into the frame channel corner A. Repeat for the opposite corner B. Repeat for the next corner C. Lastly, repeat for the final corner D.
2. After all corners are pressed in, press the silicone into the frame channel at the mid-points on all four sides.
3. Press silicone into frame evenly between the corner and midpoints.
This prevents the graphic from bunching up or stretching too much and will ensure a smooth and tight fit.
4. To remove the graphic from the frame, simply pull up on the pull tag.
5. Repeat steps 1 to 4 for the additional graphics. *Note: the outside facing graphics are wider than the inside facing graphics.*
6. Use eyebolts on frame to hang the assembly.
7. Plug in the power cords. *Note: The light box will have multiple power cords.*

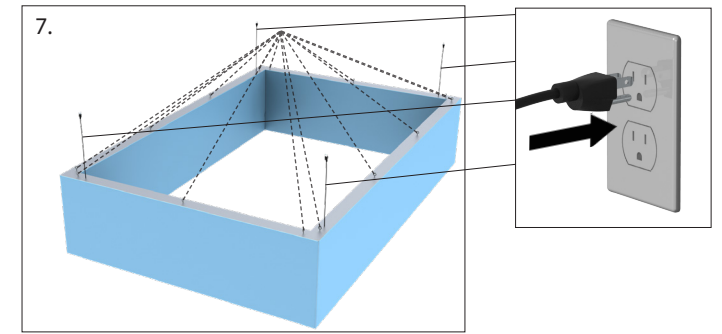
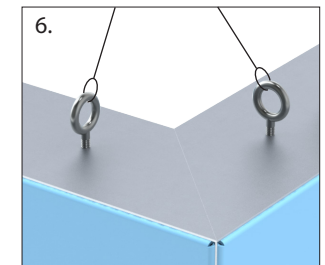
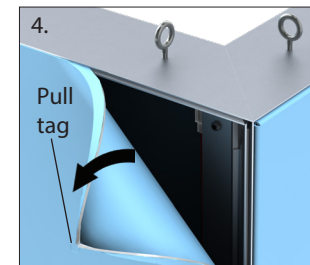
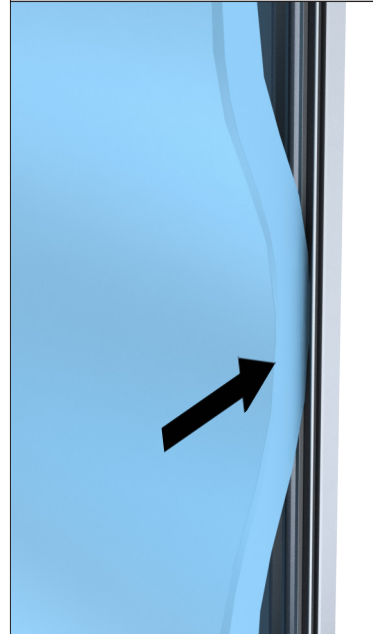
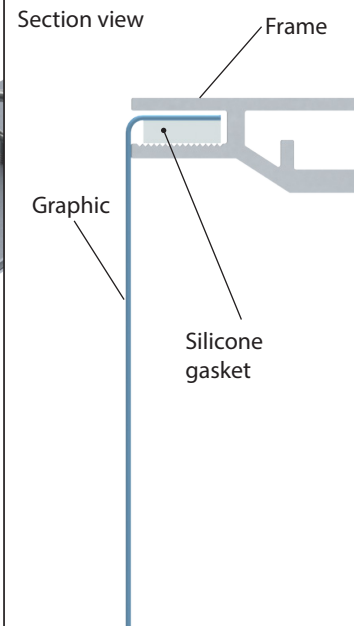
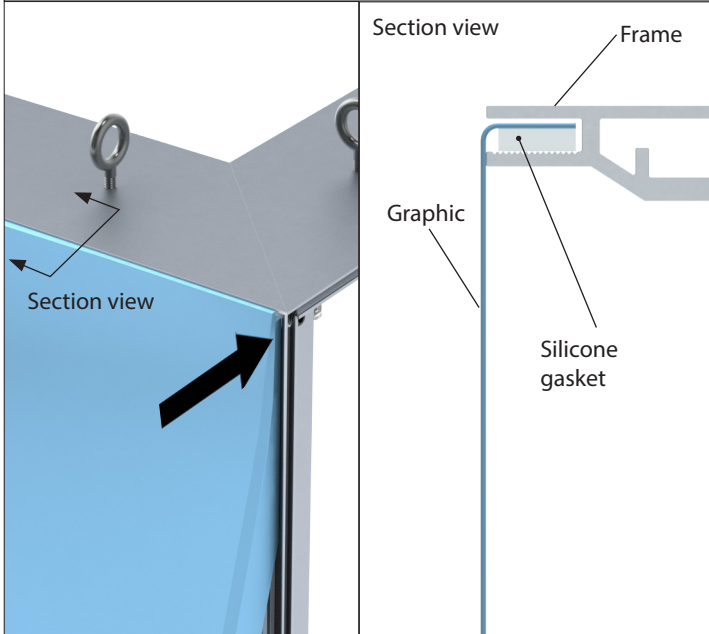
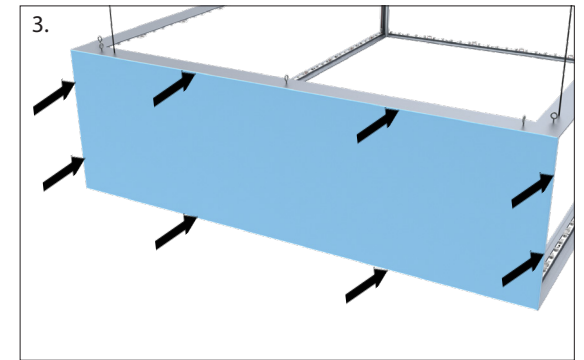
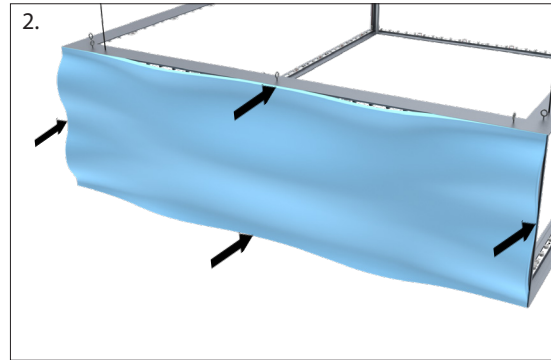
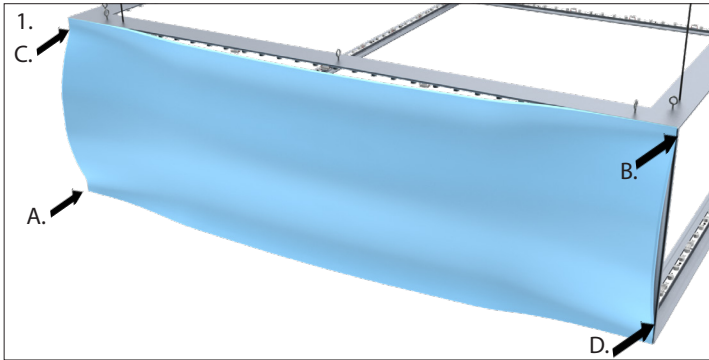
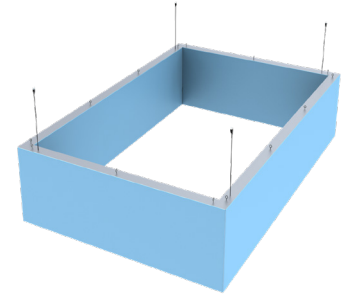

Charisma Inside-Out Light Box™ - XSIO Series

PROFESSIONAL INSTALLATION
WITH MULTIPLE PEOPLE IS RECOMMENDED

Identify the various Frame Assembly Components as shown below. First start by assembling corners. There are two (2) flat L-brackets per corner. All extrusion sections are numbered to identify which pieces go together, 1 with 1, 2 with 2, etc.

1. For the Bottom frame section, join the corner sections of the bottom portion of the frame using the L-brackets and screws. Join the mid sections using the flat joiner plates and screws as shown below.
2. Repeat step 1 for the Top section with eyebolts attached (not shown).
3. Connect the corner supports and fasten to bottom section using the hex key provided.

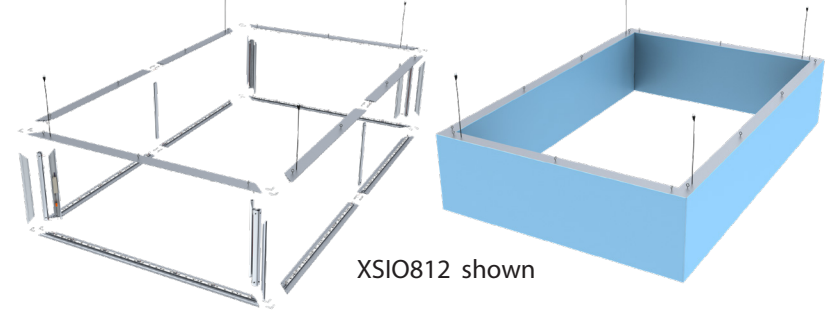

Frame Assembly Components

- Frame Top/Bottom
- Center Support
- Corner Support
- Outside Corner
- Inside Corner

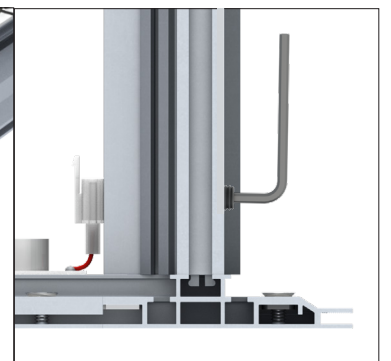
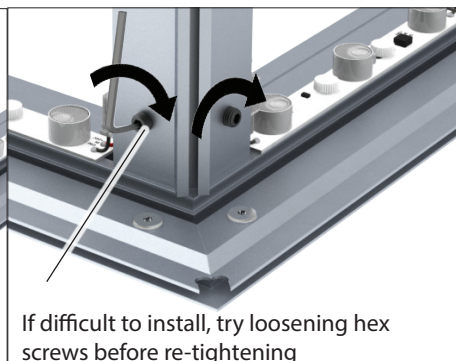
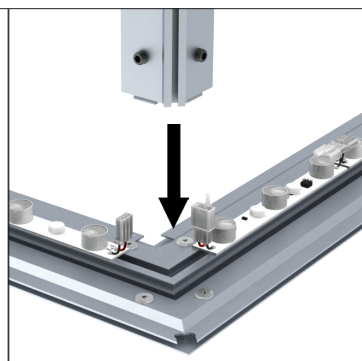
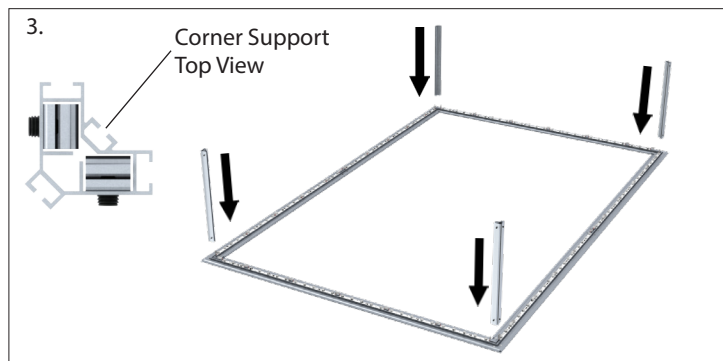
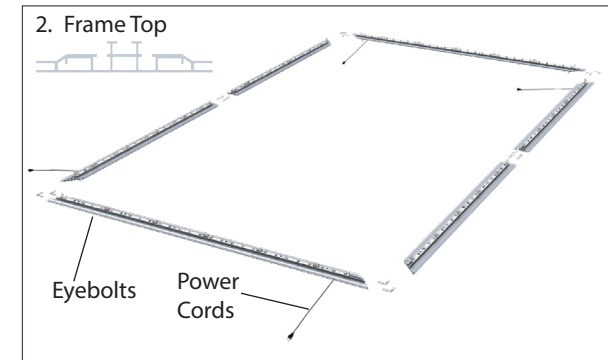
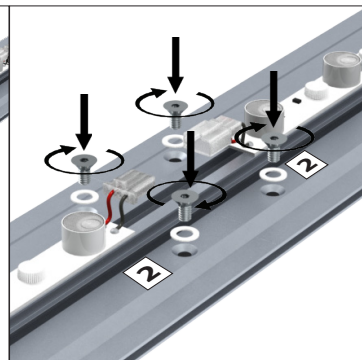
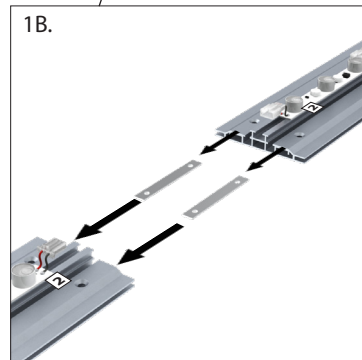
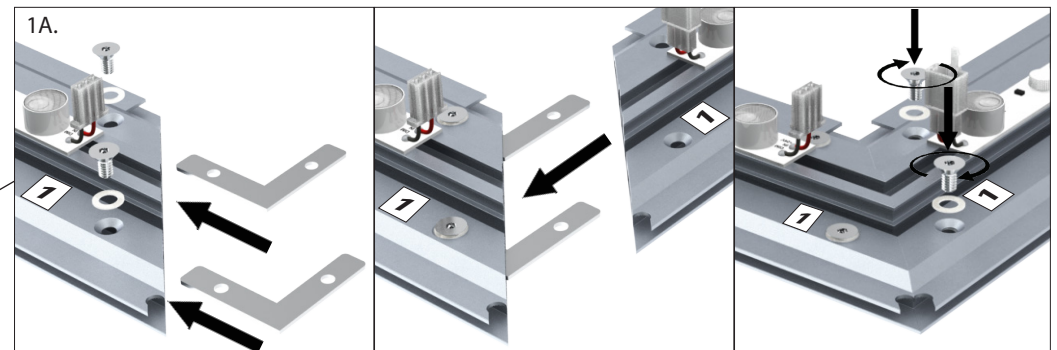
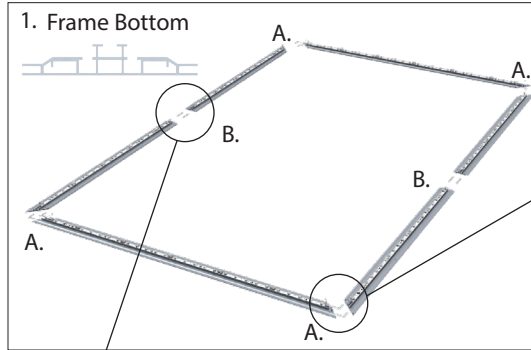

Charisma Inside-Out Light Box™ - XSIO Series

Inner and outer extrusions should fit into the notches of the top and bottom frame extrusions. If it doesn't fit, carefully jiggle the extrusions until they fit in. Don't force it.

1. Identify the outer corner extrusion, pictured below.
2. Slide outside corner extrusion down channel of upright section as shown below, slowly lowering it into place. The corner of the extrusion will sit into the notched space of the bottom frame corner. Do not force or drop into place.
3. Slide inside corner extrusion down channel of upright section as shown below, slowly lowering it into place. The corner of the extrusion will sit into the notched space of the bottom frame corner. Do not force or drop into place.

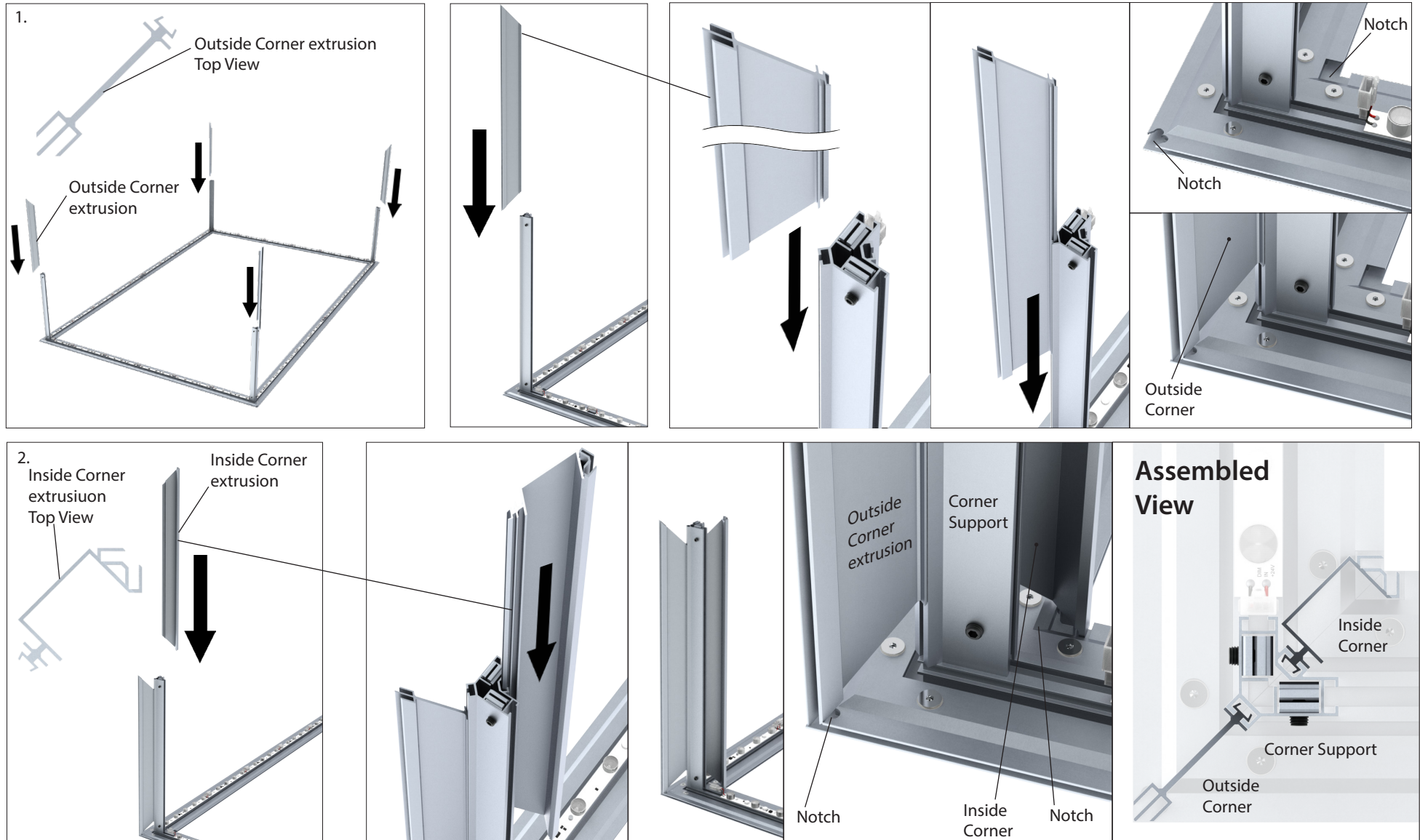

Charisma Inside-Out Light Box™ - XSIO Series

1. Attach the Top frame section to the uprights and fasten the screws using the hex key provided. Corners of outside and inside extrusions will sit in the notches of the top of the frame.
2. Insert the vertical supports into the channel of the Top and Bottom sections, and fasten the ends using the hex key provided. Make sure to use all vertical supplies provided.

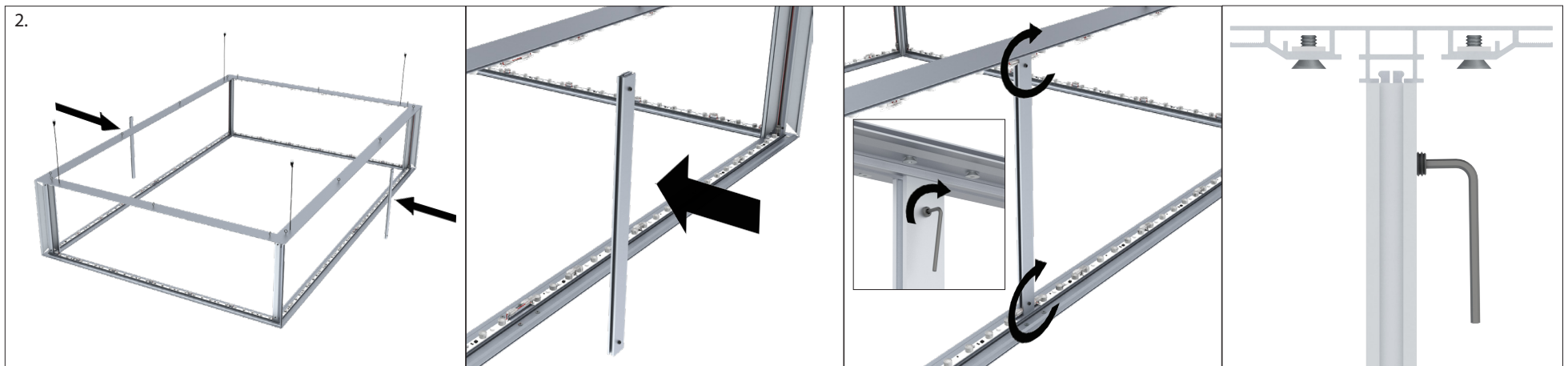
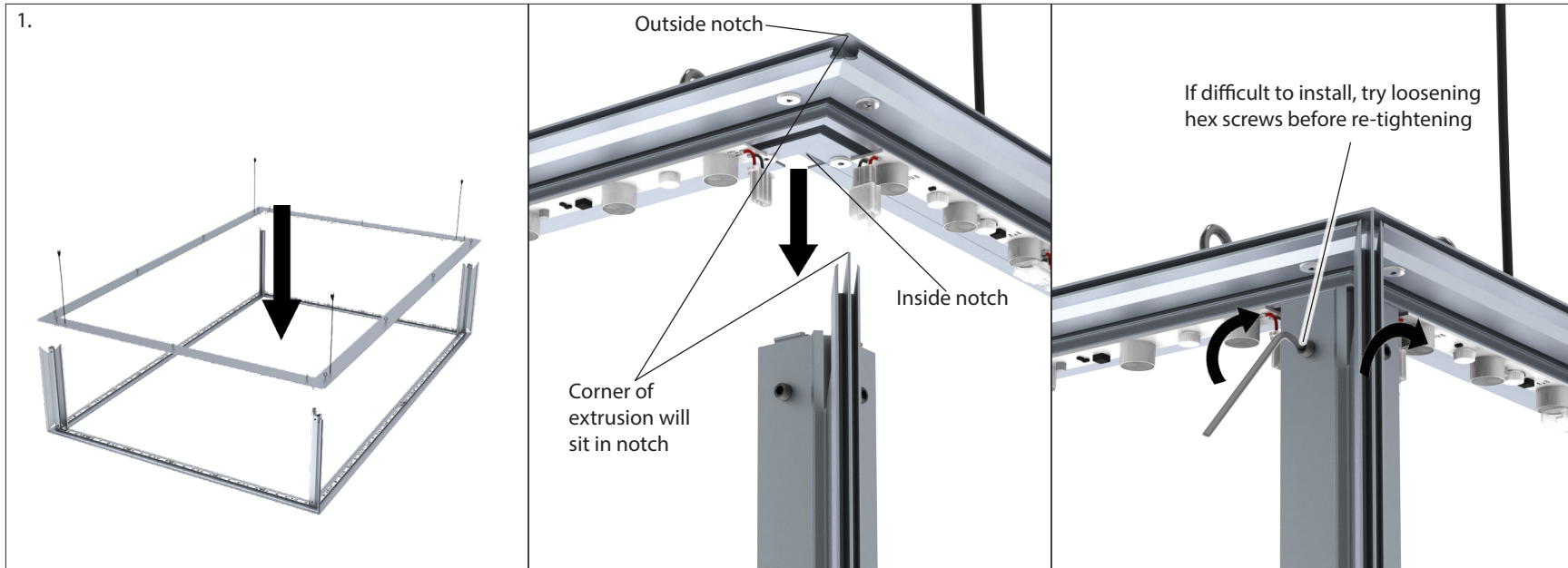

XSIO812 shown

Charisma Inside-Out Light Box™ - XSIO Series

1. At each break in the extrusion, identify the orange or white electrical connector. Then connect the white female connectors to their matching male connectors and the orange female connector to their matching male connector. The connectors must fully "click" together.
2. It is normal for the last female white connector to be unconnected to anything else.
3. If there are multiple cables, connect those with matching colors (not shown).

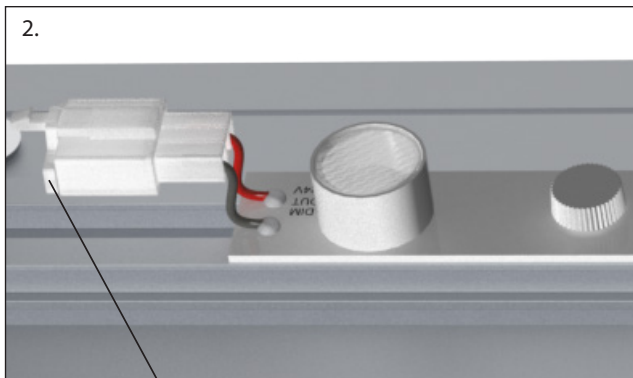
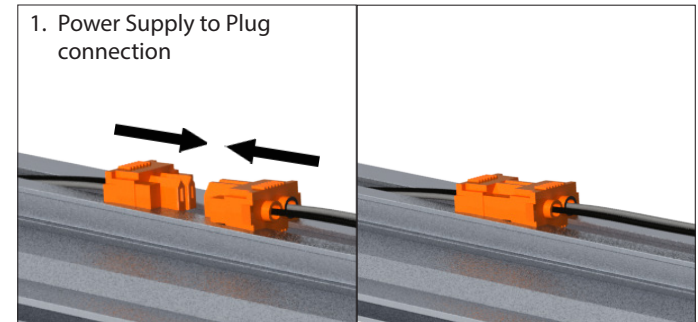
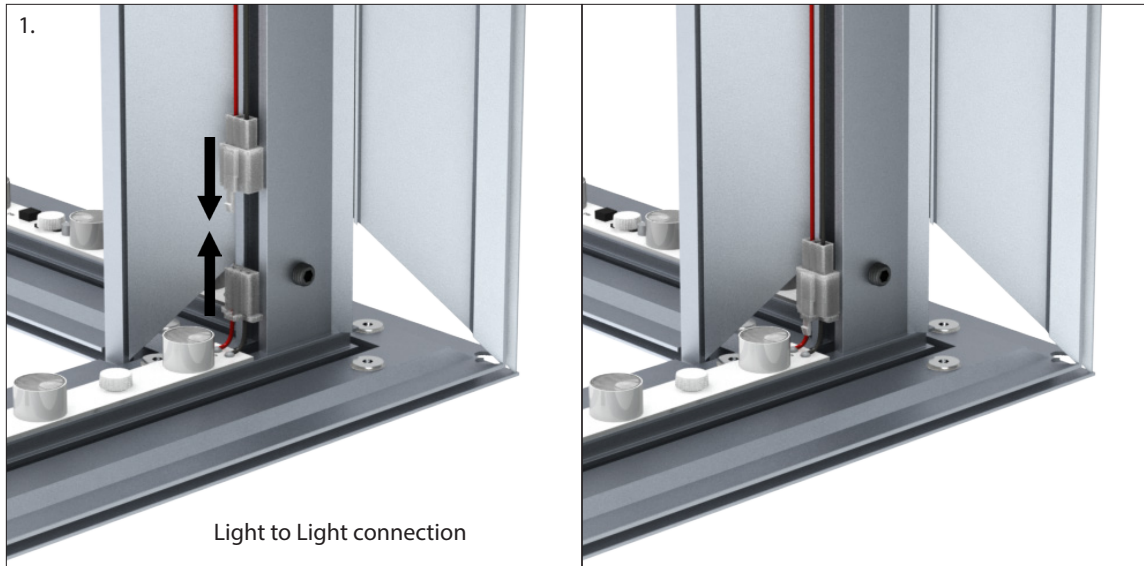

Unconnected last female connector is normal

Charisma Inside-Out Light Box™ - XSIO Series

Follow the steps below to install the INSIDE face graphics FIRST, then proceed to installing the outside face graphics.
Outside face graphic is shown in the steps below for clarity.

1. To install the graphic, take the corner with the pull tag on it and press about 6"-10" of silicone into the frame channel corner A. Repeat for the opposite corner B. Repeat for the next corner C. Lastly, repeat for the final corner D.
2. After all corners are pressed in, press the silicone into the frame channel at the mid-points on all four sides.
3. Press silicone into frame evenly between the corner and midpoints.
This prevents the graphic from bunching up or stretching too much and will ensure a smooth and tight fit.
4. To remove the graphic from the frame, simply pull up on the pull tag.
5. Repeat steps 1 to 4 for the additional graphics. *Note: the outside facing graphics are wider than the inside facing graphics.*
6. Use eyebolts on frame to hang the assembly.
7. Plug in the power cords. *Note: The light box will have multiple power cords.*

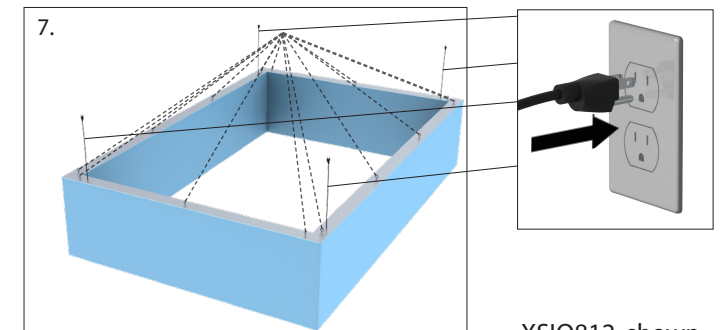
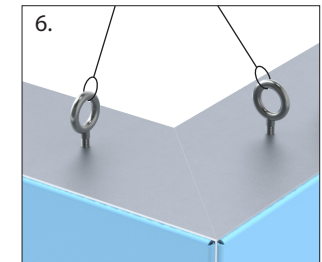
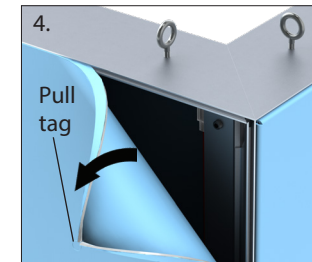
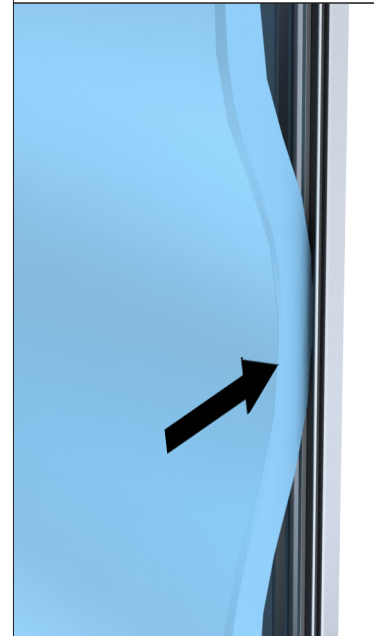
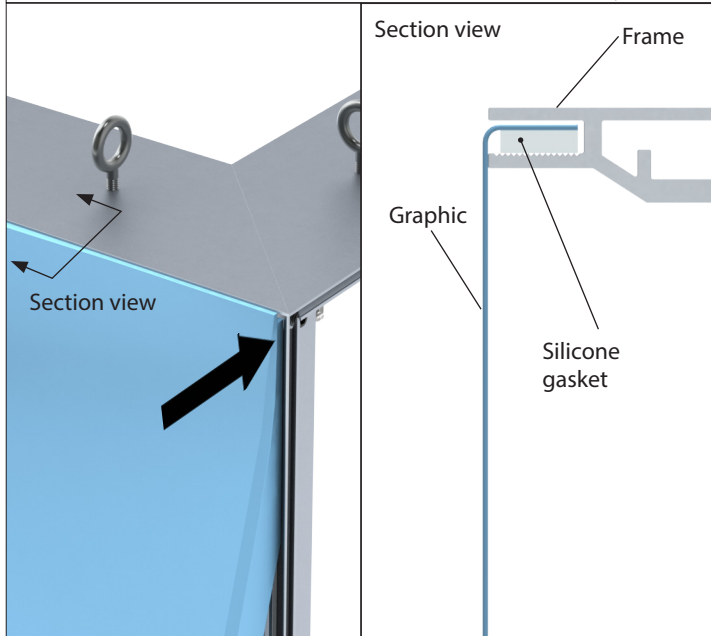
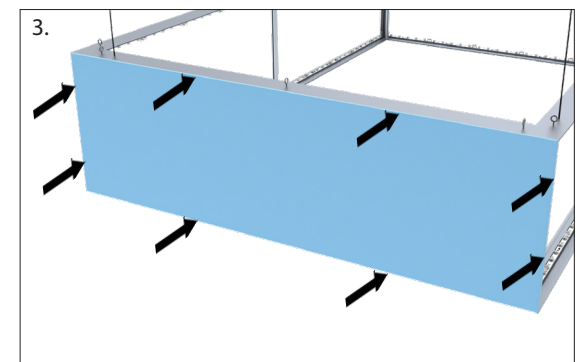
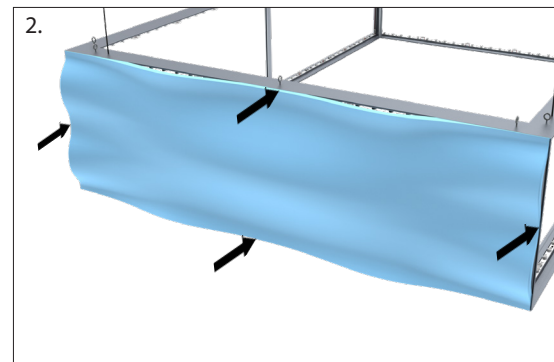
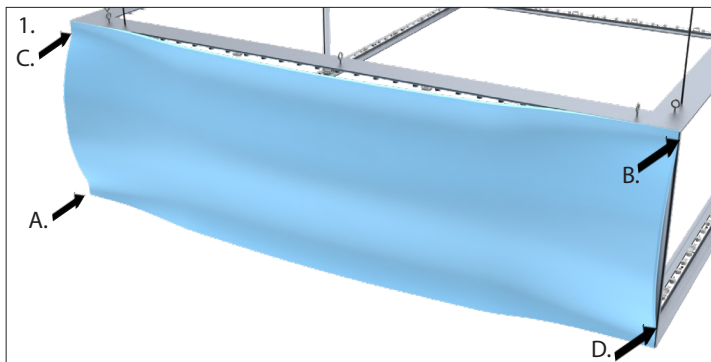
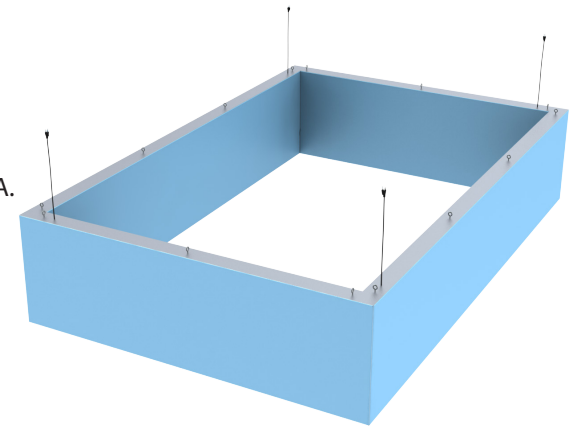

XSIO812 shown