

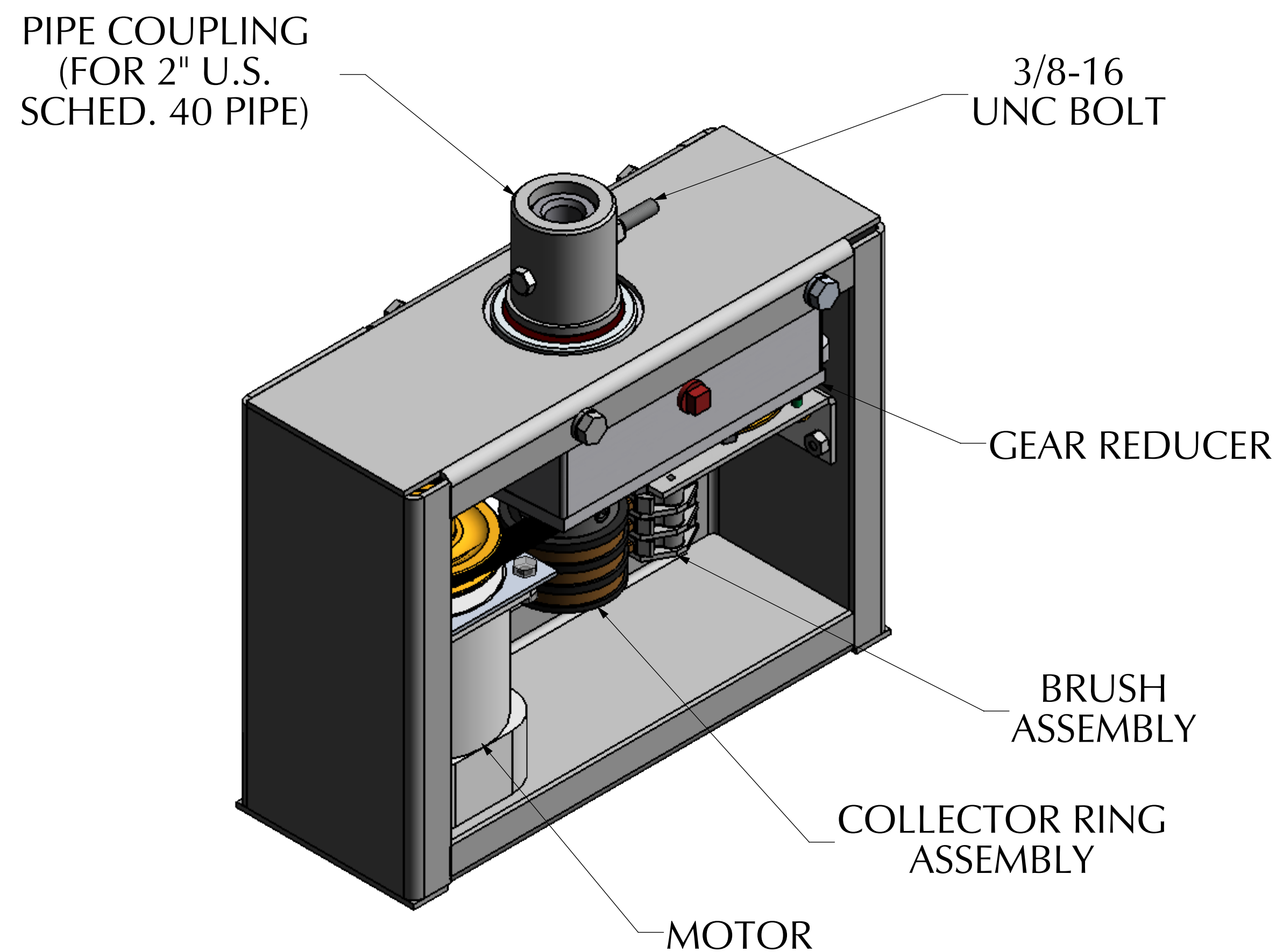

H-20 With 2" Pipe Coupling

Part Number: 134009 321

Hanging Weight Capacity.....500 lbs [226.8 kg]
 Compressive Weight Capacity.....400 lbs [181.4 kg]
 Max Display Size.....Contact Dynapac
 Standard RPM.....2
 Torque Output @ 2 RPM.....192 in-lbs [21.7 Nm]
 Motor Draw.....1.1 A (127 watts)
 Safety Clutch.....Standard Feature
 Collector Ring Capacity.....15A at 115 V
 Shipping Weight.....31 lbs [14.0 kg]

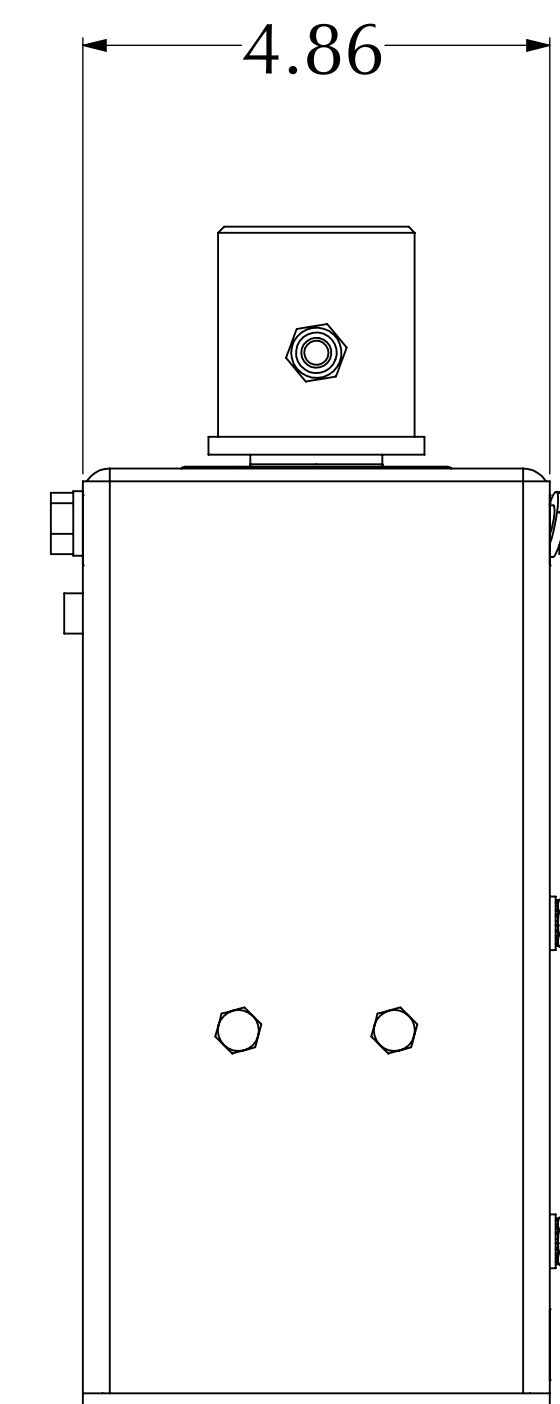
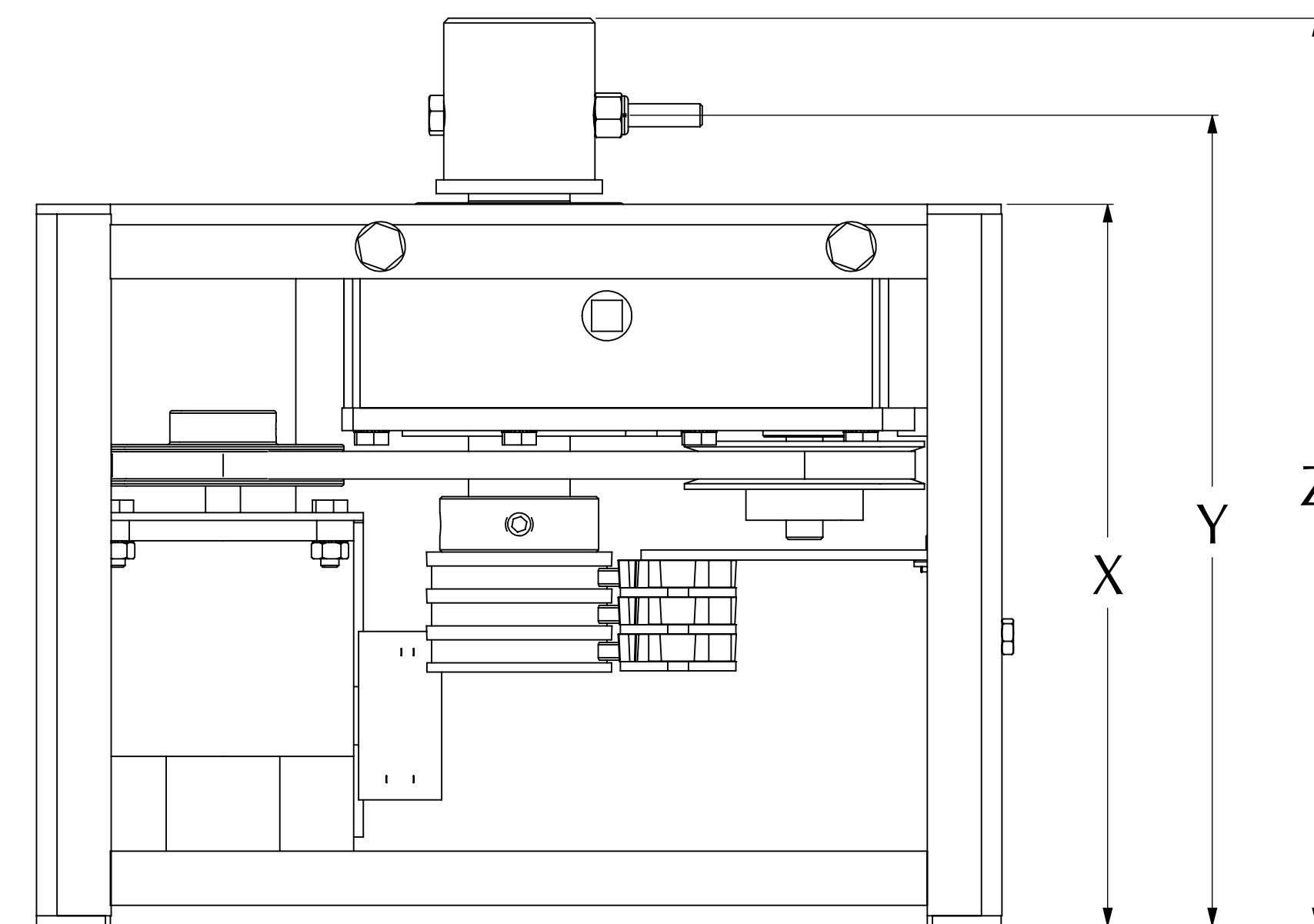
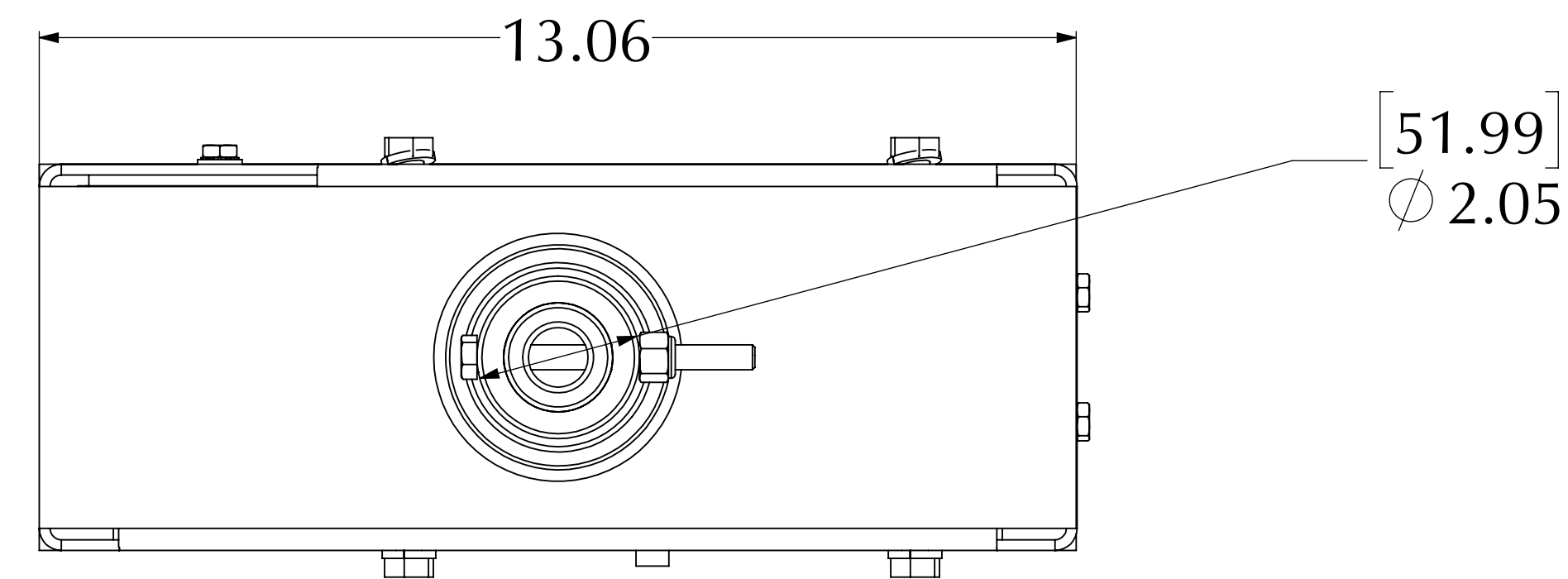

	X	Y	Z
STANDARD FRAME (6 RING)	9.77" [248.16mm]	10.97" [278.74mm]	12.29" [312.09mm]
8 RING FRAME	10.77" [273.56mm]	11.97" [304.14mm]	13.29" [337.49mm]
12 RING FRAME	13.02" [330.71mm]	14.22" [361.19mm]	15.54" [394.72mm]

Dynapac Rotating Company Inc.
 338 Hansen Ave., Salt Lake City, UT 84115
 Phone: 801-485-2221 • Fax: 801-485-2254
 email: info@dynapacrotating.com • www.dynapacrotating.com