

# Linear Kiosk 05

LN-K-05

Dress up and add wow to your space with state-of-the-art multimedia kiosks.



We are continually improving and modifying our product range and reserve the right to vary the specifications without prior notice. All dimensions and weights quoted are approximate and we accept no responsibility for variance. E&OE. See Graphic Templates for graphic bleed specifications.

## features and benefits:

- Custom appearance
- Easy to assemble
- Bases & tops available in four color options
- Aluminum construction: vertical extrusions 50 mm x 50 mm
- Installation tool included
- Comes with your choice of frosted plex or PVC graphic panels
- Kit includes one OCH case
- Lifetime hardware warranty against manufacturer defects

## dimensions:

Hardware	Graphic
<b>Assembled unit:</b> 25.4" w x 72" h x 18.5" d approx. 646mm(w) x 1830mm(h) x 471mm(d)	<b>Left panel:</b> Total visible area: 15.25" w x 32.125" h 387mm(w) x 816mm(h)
<b>Shipping</b>	<b>Right panel:</b> Total visible area: 15.25" w x 32.125" h 387mm(w) x 816mm(h)
<b>Shipping dimensions</b> - ships in one case OCH case: 48" l x 24" w x 10" h 1219mm(l) x 610mm(w) x 254mm(h)	<b>Center panel:</b> Total visible area: 18" w x 31.125" h 457mm(w) x 790.5mm(h)
<b>Approximate shipping weight (entire kit):</b> 60 lbs/27.21kg	Refer to related graphic template for more information

## additional information:

**Panel materials:**  
 Single-sided frosted acrylic or printed PVC

**Base & table top color options:**



Easy locking panel storage space

Small LCD monitor mount included:  
 Monitor mount supports monitor size range 13" - 27"  
 Max monitor weight 25 lbs.

Parts Included

Part Code	Qty.	Part Description
PHFC2-150-L	x2	150MM PHFC2 W/ONE LOCK AND CAP
PM2R8-50	x2	PM2R8 50MM (2") BASE
PH4-200	x2	PH4 200MM (7.875") WITH TENSION GLIDES PINED TO PM2R8-50
LN-K-TBL1*	x1	LINEAR KIOSK TABLE COUNTER 1 (*MATERIAL FINISH MAY VARY)
LN-K-TBL2*	x1	LINEAR KIOSK TABLE 2 (*MATERIAL FINISH MAY VARY)
PH-457-L-L	x2	457MM (17.9") PH EXTRUSION WITH LOCKS 2 ENDS
PM2R8-MCAP	x4	PM2R8 GREY MOLDED CAP
PM2R8-839-L	x2	839MM (33") 50MM PM2R8 8 WAY ROUND EXTRUSION
PM2R8-900-A	x2	900MM (35.43") 50MM PM2R8 8 WAY ROUND EXTRUSION WITH STOP AT 155MM
LN-G-K-05A*	x2	LINEAR KIT 5 GRAPHIC PANEL A (*MATERIAL FINISH MAY VARY)
LN-G-K-05B*	x1	LINEAR KIT 5 GRAPHIC PANEL B (*MATERIAL FINISH MAY VARY)
PH4SC-300	x1	300MM PH4SC WITH TENSION GLIDES
LN100	x2	LINEAR JOINING BAR
LN-LCD1-B	x1	13"-27" FLATSCREEN BLACK LINEAR LCD MONITOR MOUNT FOR SMALL
WME-800	x2	WME 800MM (31.5") WIRE MANAGEMENT EXTRUSION
ALLEN KET SET	x1	ALLEN KEY MULTI-TOOL
OCH	x1	OCH SHIPPING CASE

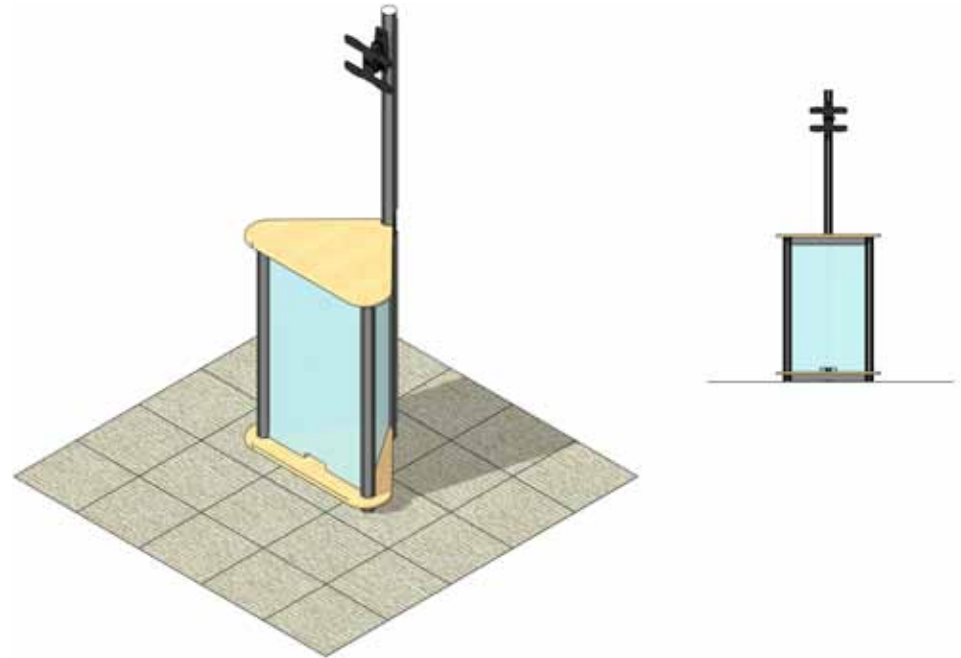

Step 1.

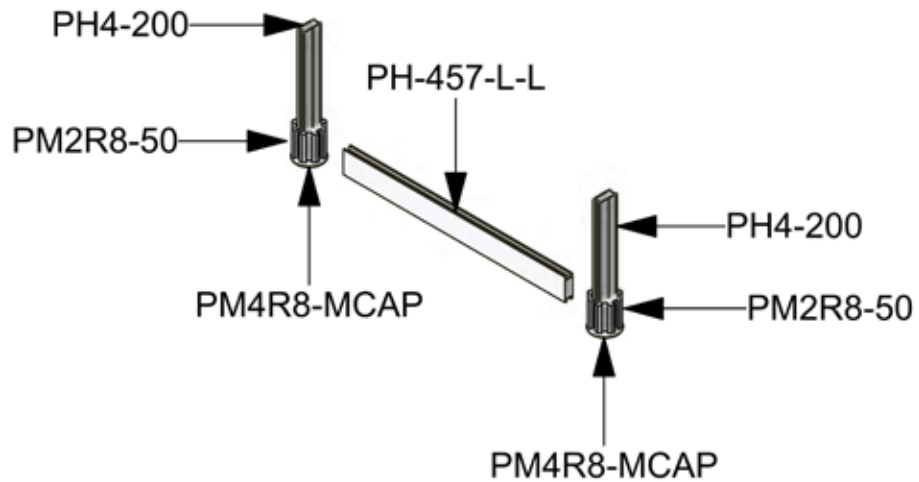
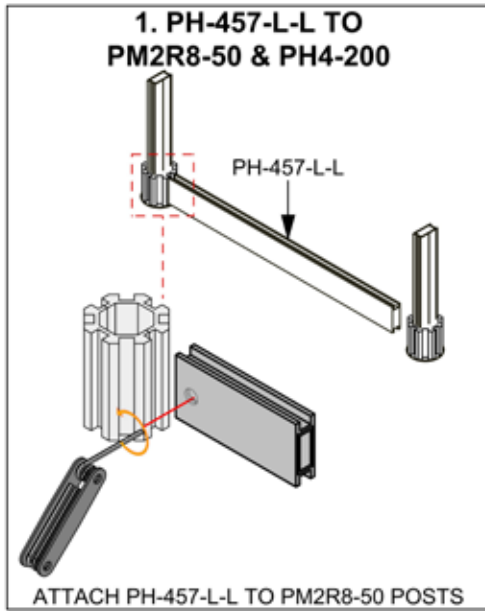

Step 2.

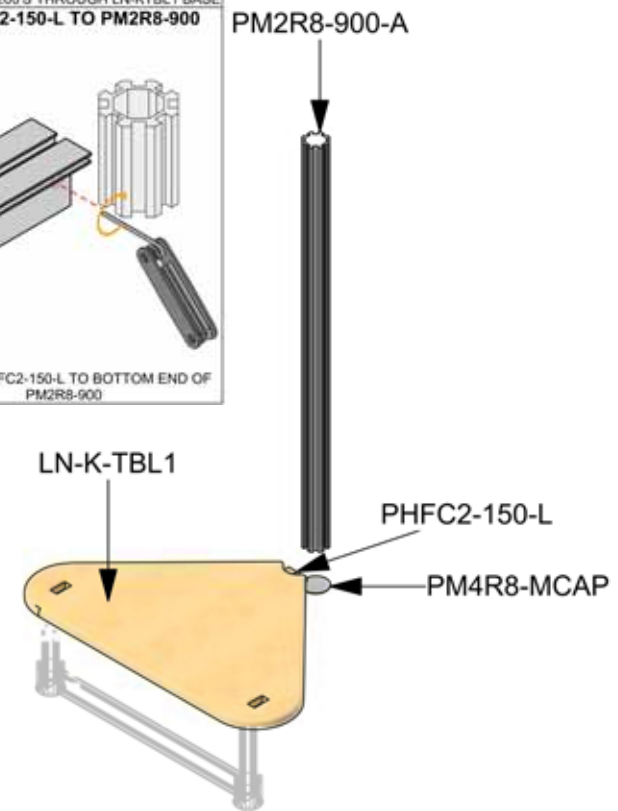
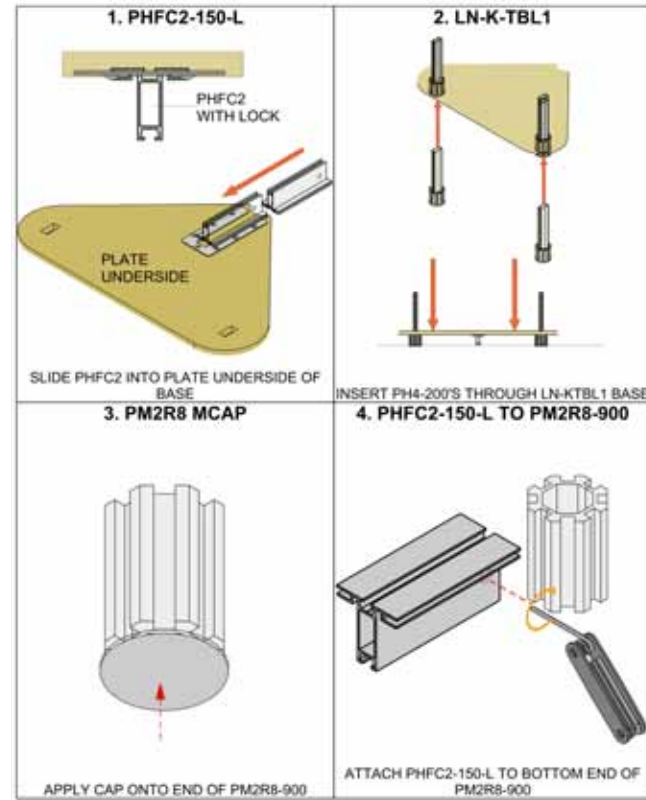

Step 3.

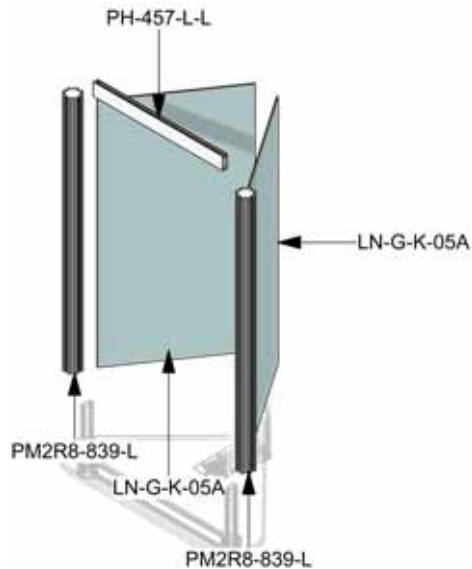
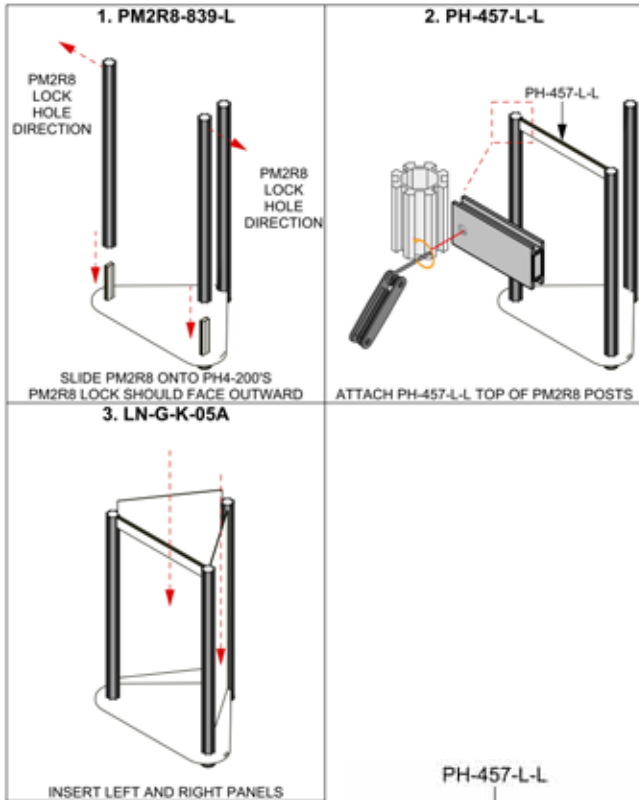

Step 4.

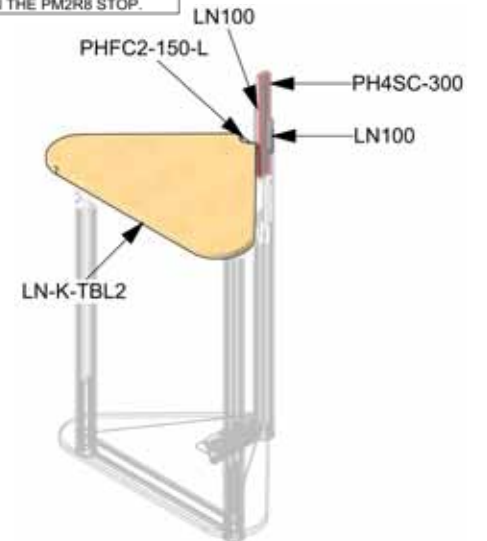
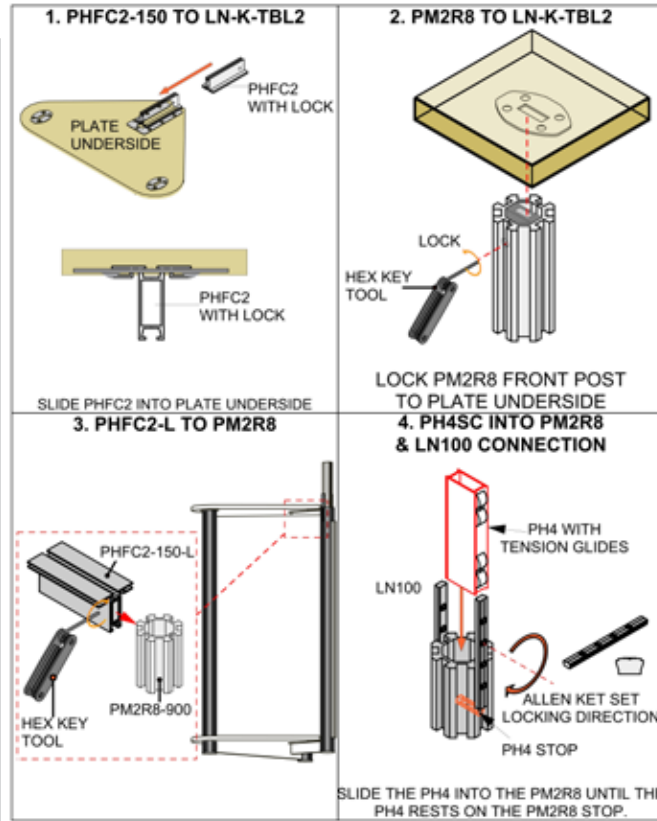

Step 5.

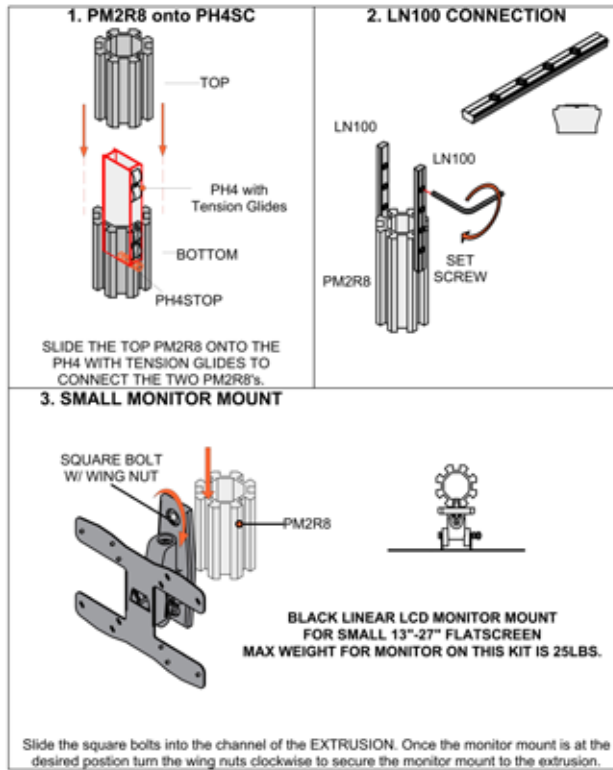

Step 6.

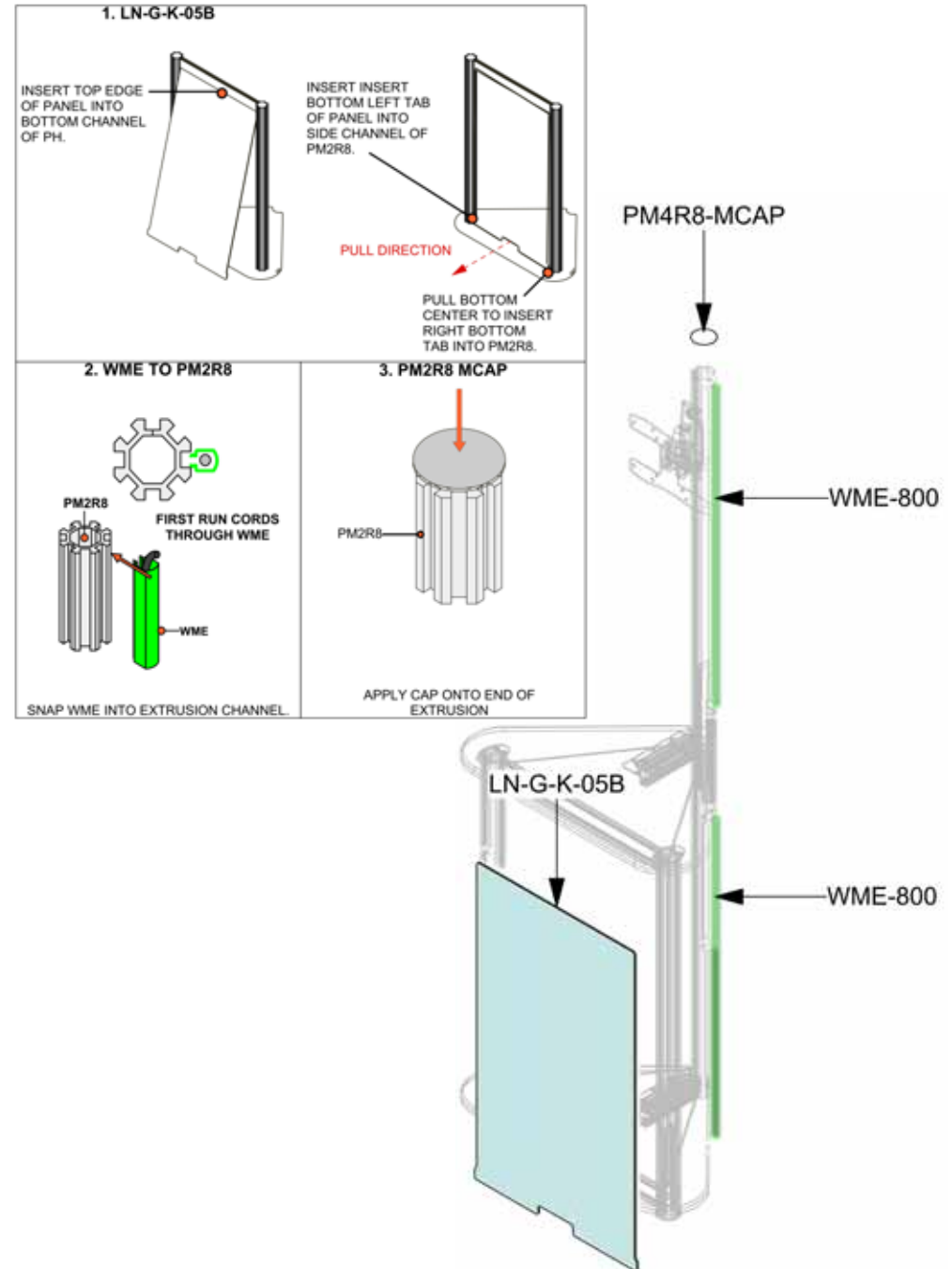

## Check out these related products:

---



Linear Kiosk 05



Linear Kiosk 06



Linear Kiosk 07



Linear Kiosk 08

---