

Step 1. Attach lower cross bars to verticals.

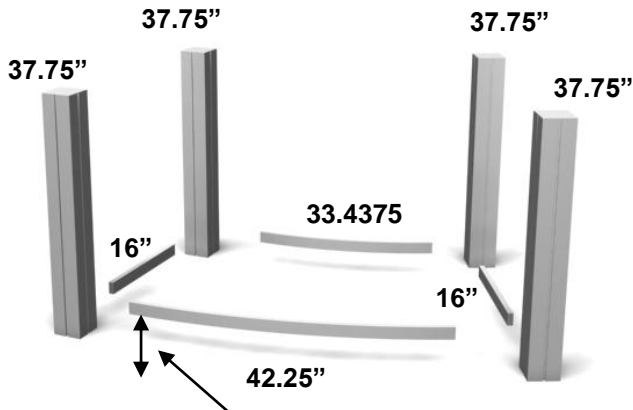

**** Bottom of cross bars to be 8.25" off floor ****

Step 2. Insert back and side panels.

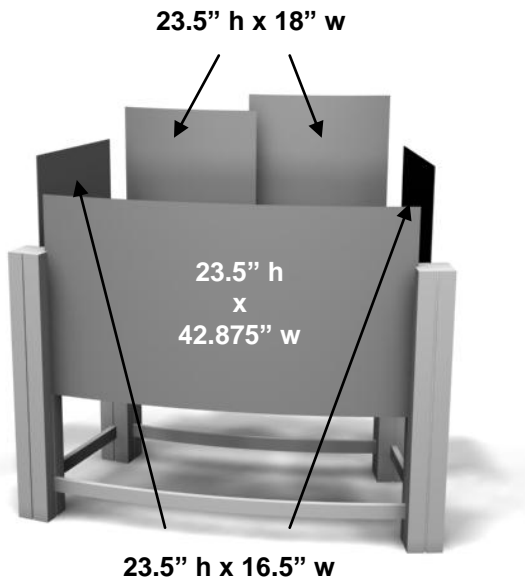

Step 3. Attach upper cross bars to verticals.

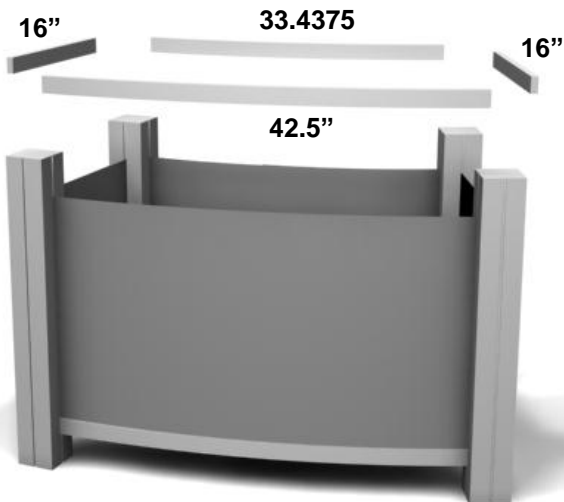

Step 4. Place counter top in position.



Step 5. Screw in 8" long standoffs, attach upper counter.



Step 6. Insert upper infills.

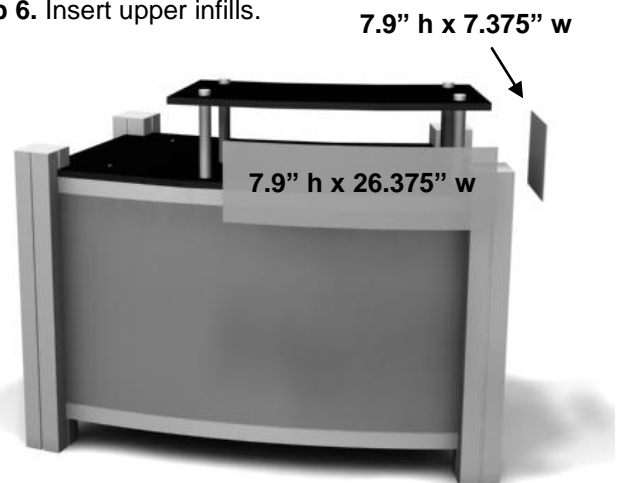

Step 7. Screw in 2" long standoffs, attach middle counter.



Step 8. Attach optional wing using knobs & grippers.



// CrossBar Detail //

