



IG-2 HANG Less Collector Ring

Part Number: 154001 021HANG

Dependable performance, durable construction and safety conscious; the IG-2 HANG comes with Dynapac's exclusive torque relief clutch that slips harmlessly if turning motion is obstructed to prevent personal injury and keep the motor from burning out.

Hanging Weight Capacity.....100 lbs [45 kg]
 Compressive Weight Capacity.....100 lbs [45 kg]
 Max Display Size.....10' x 10' [3m x 3m]
 Standard RPM.....2
 Torque Output @ 2 RPM.....24 in-lbs [2.7 Nm]
 Motor Draw.....0.1A (12 watts)
 Safety Clutch.....Standard Feature
 Shipping Weight.....9 lbs [4.1 kg]

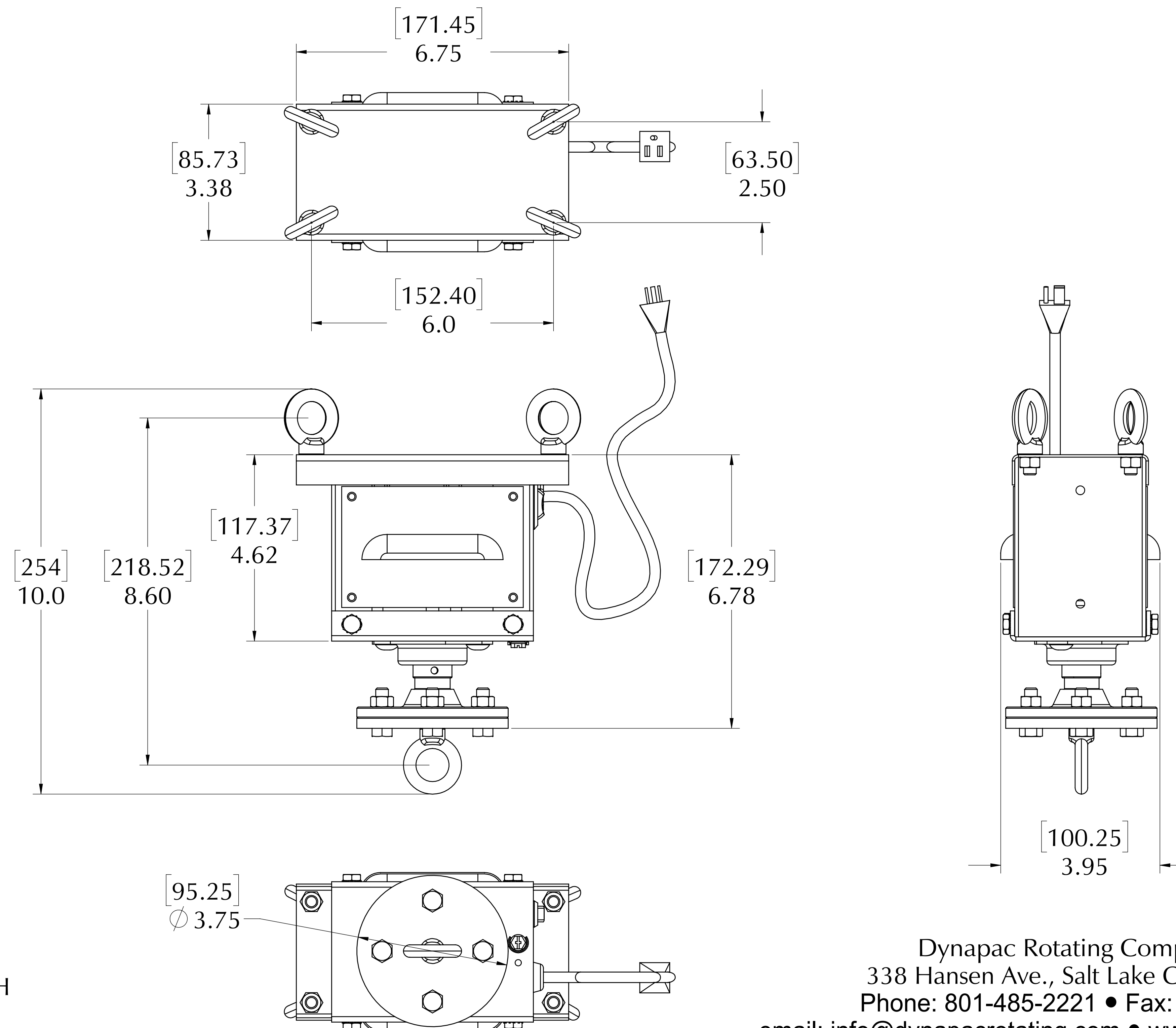
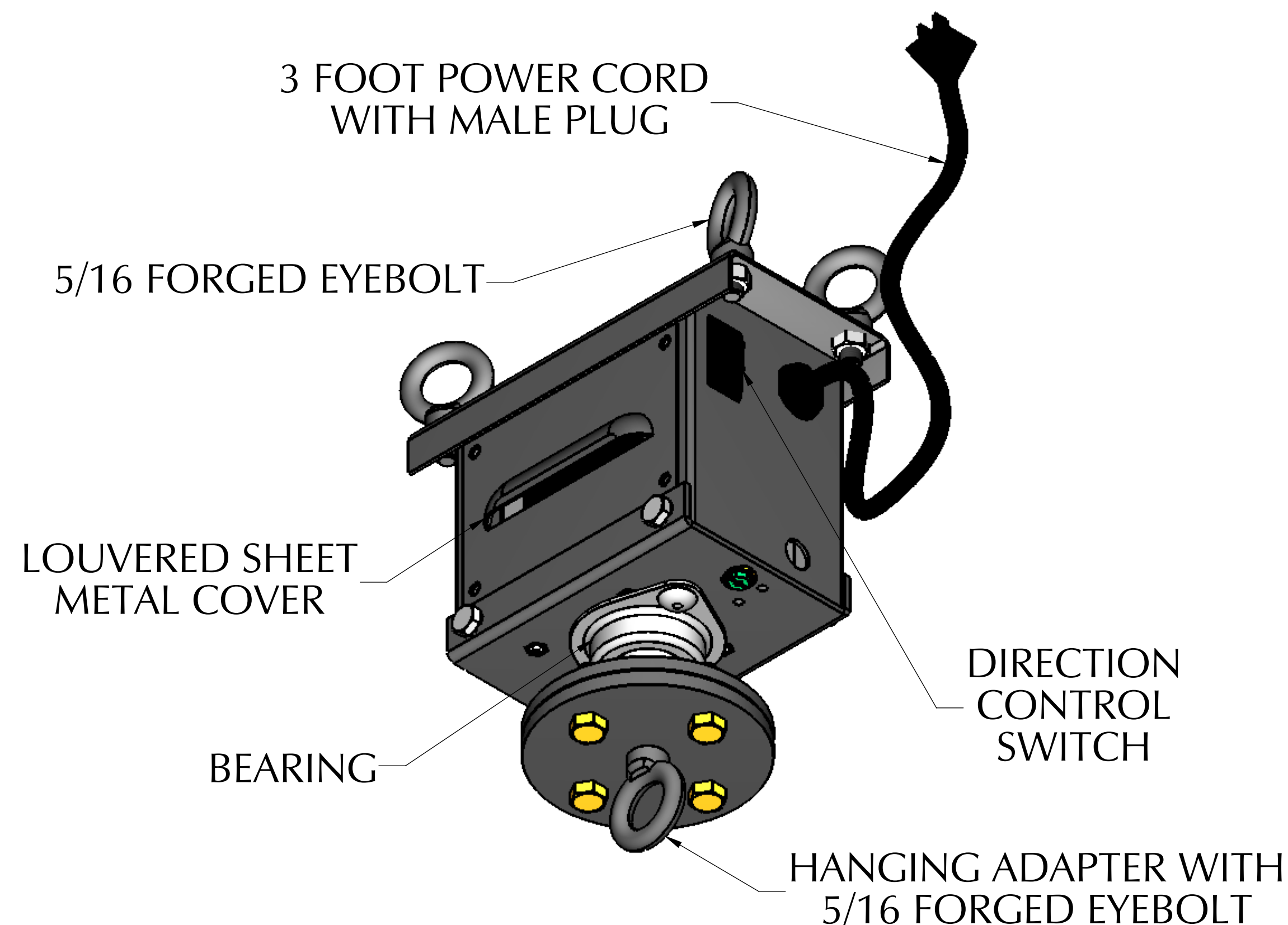

Dynapac Rotating Company Inc.
 338 Hansen Ave., Salt Lake City, UT 84115
 Phone: 801-485-2221 • Fax: 801-485-2254
 email: info@dynapacrotating.com • www.dynapacrotating.com