



IG-4 HANG With Collector Ring

Part Number: 150001 321HANG

A compact yet powerful rotator that gives attraction to any indoor sign or display. This is a step up in size and power from the IG-2 with an ultra quiet, heavy-duty motor. Used in convention halls across the world, this unit is the standard for rotating hanging banners up to 12 feet in diameter.

Hanging Weight Capacity.....200 lbs [90 kg]
 Compressive Weight Capacity.....none
 Max Display Size.....12' x 12' [3.7m x 3.7m]
 Standard RPM.....2
 Torque Output @ 2 RPM.....39 in-lbs [4.4 Nm]
 Motor Draw.....0.1A (12 watts)
 Safety Clutch.....Standard Feature
 Collector Ring Capacity.....15A at 115 V
 Shipping Weight.....17 lbs [7.7 kg]

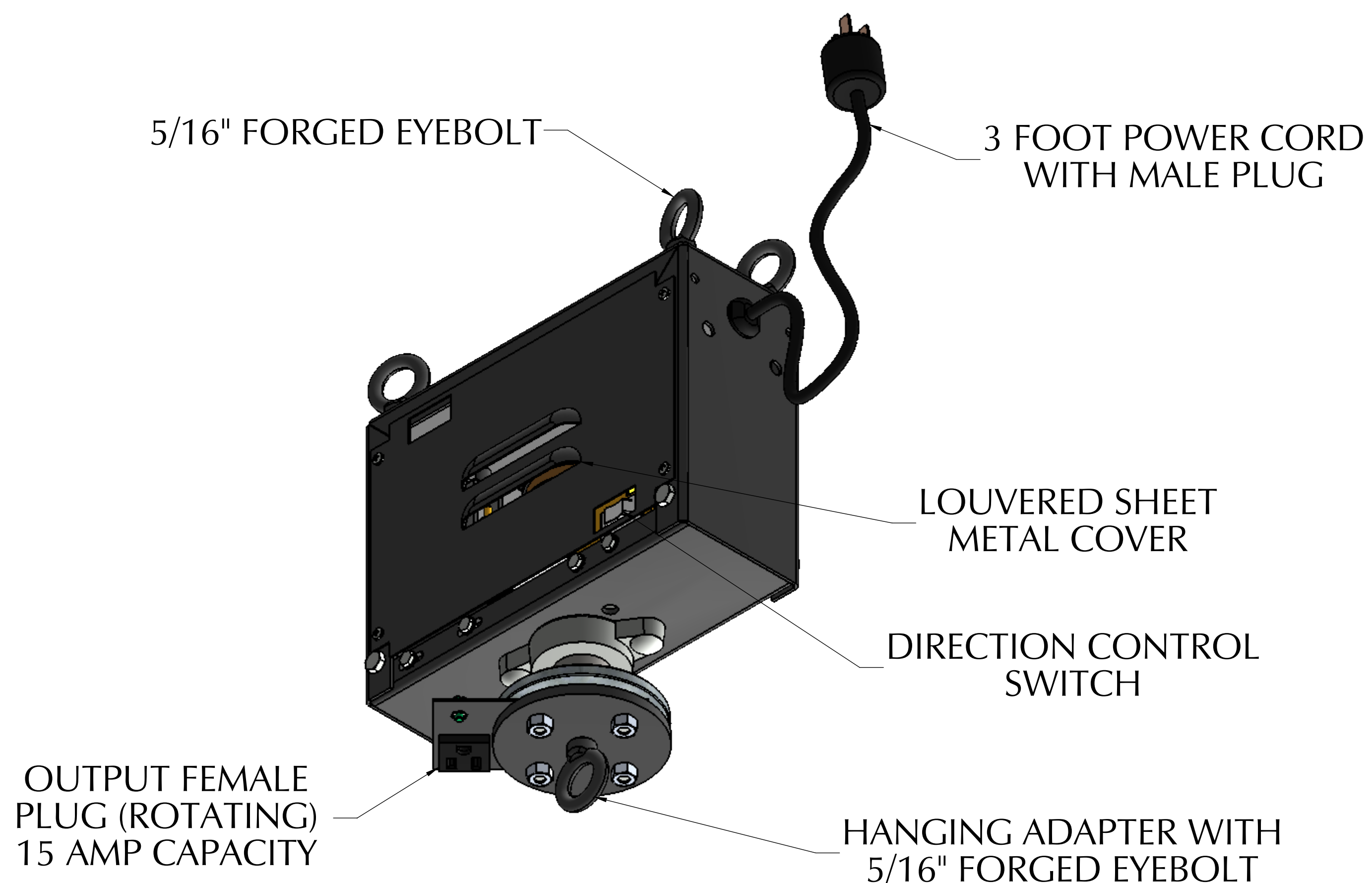
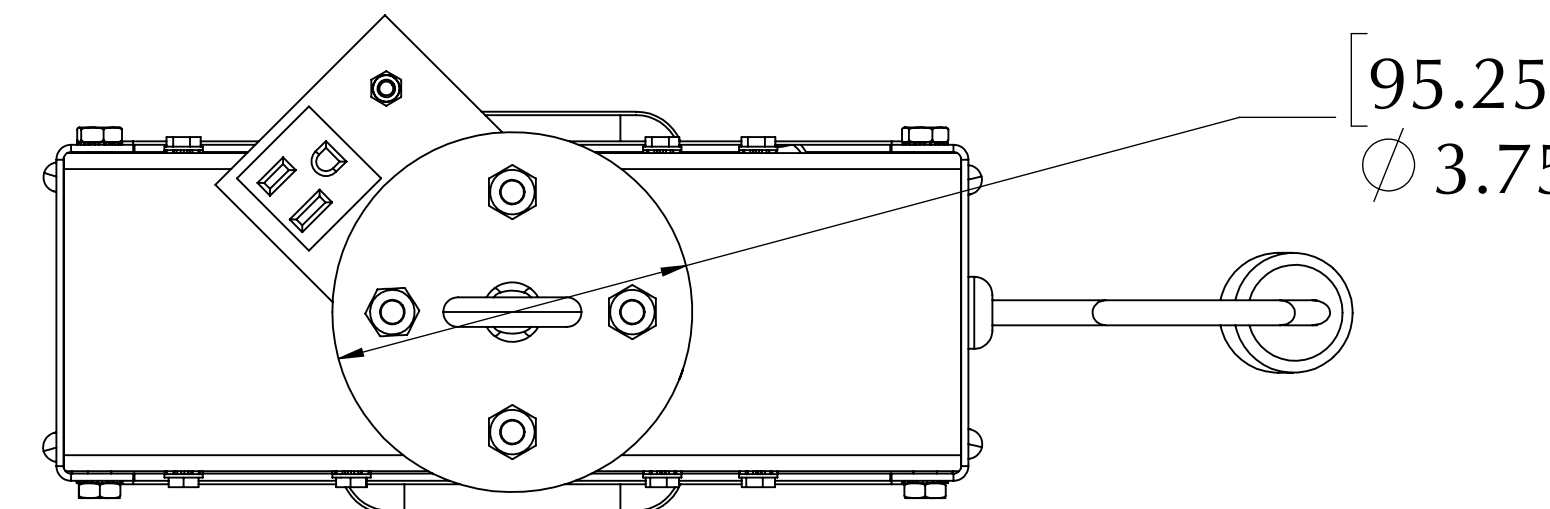
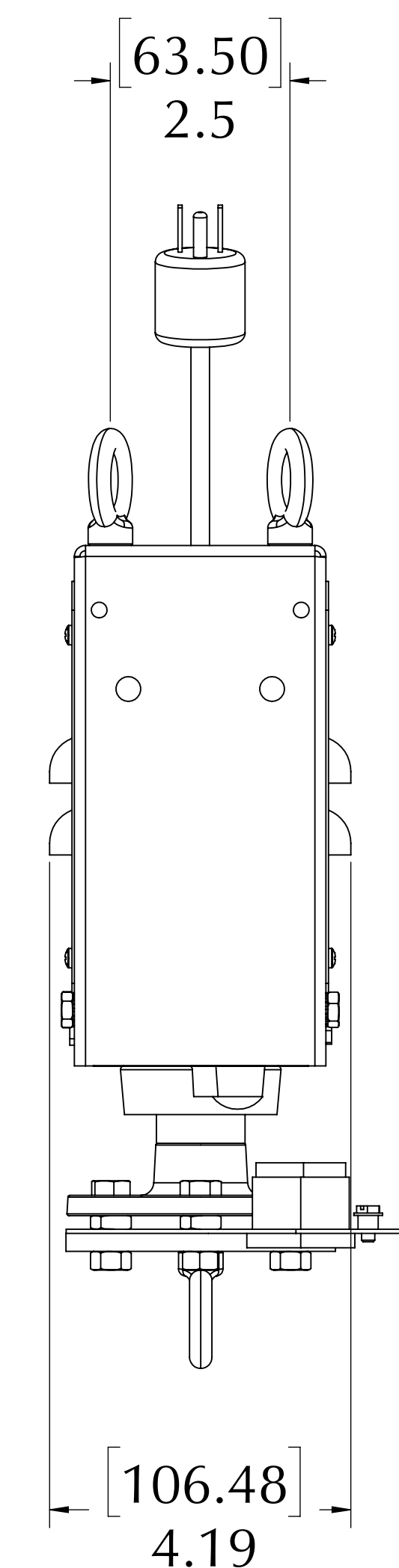
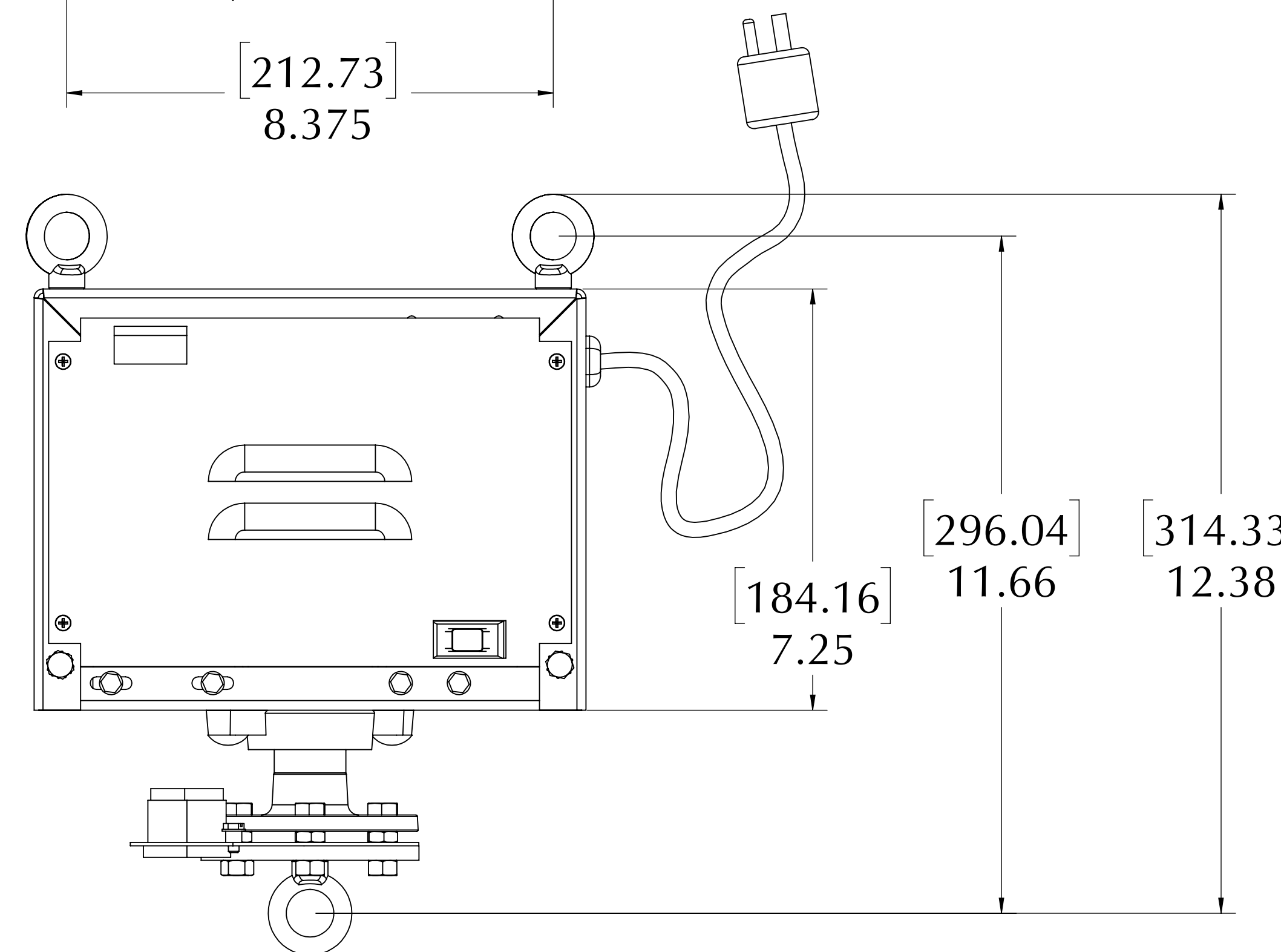
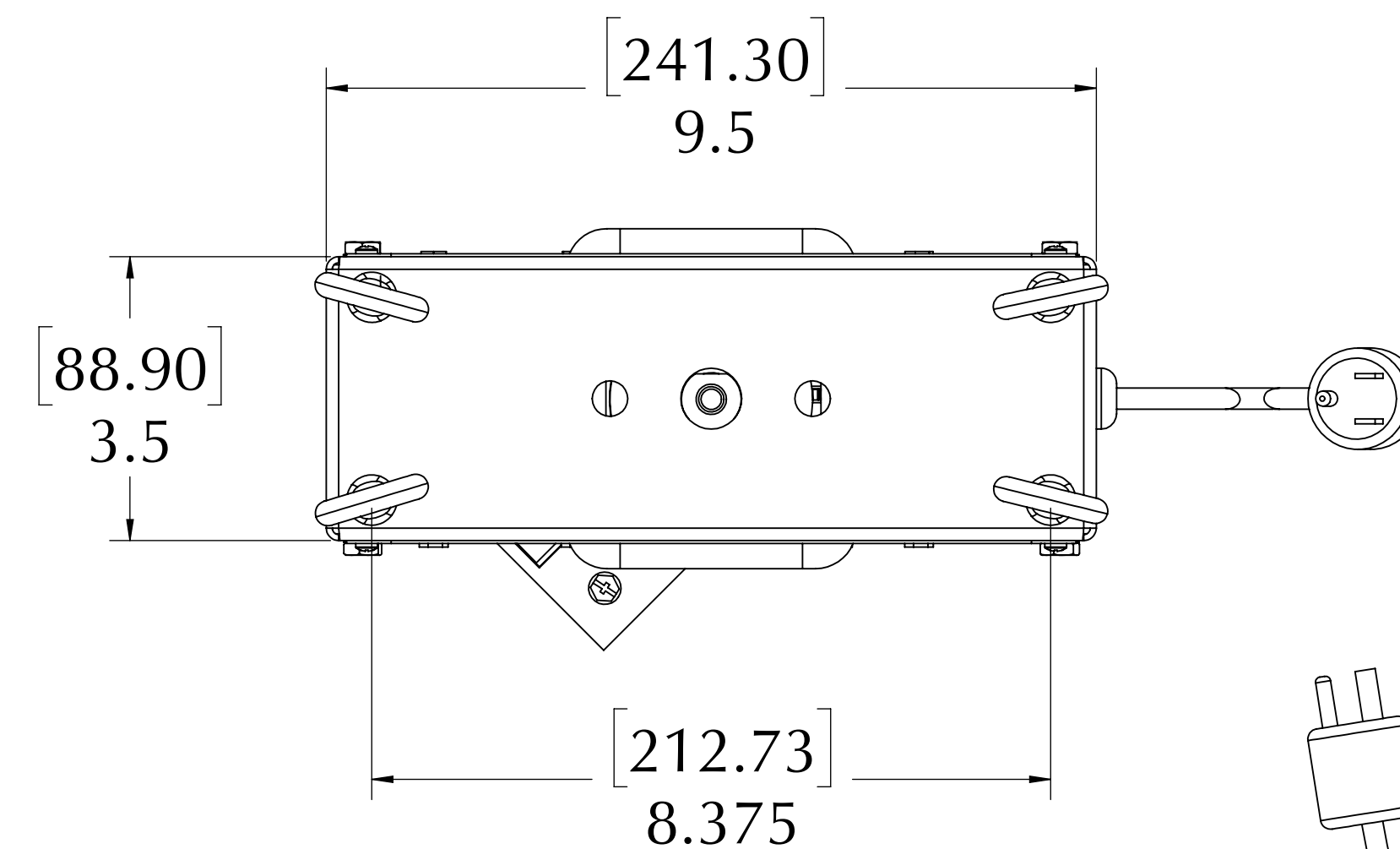

Dynapac Rotating Company Inc.
 338 Hansen Ave., Salt Lake City, UT 84115
 Phone: 801-485-2221 • Fax: 801-485-2254
 email: info@dynapacrotating.com • www.dynapacrotating.com