

Set Up Instructions

INFT-950L

Step 1: Open soft molded case and remove x2 vertical side frames with lights.



Step 2: Push sections together to complete each vertical side frame.

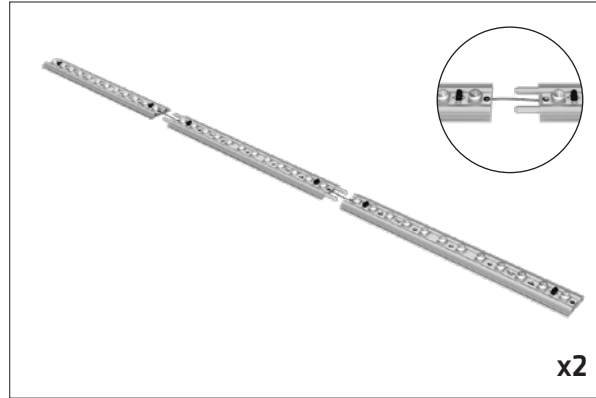

Step 3: Remove top and bottom horizontal frames.



Step 4: Join vertical side frames to top and bottom horizontal frames.

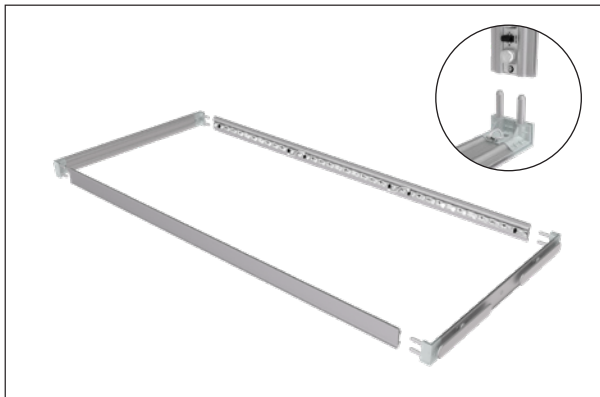

Step 5: Connect the base power cords on each side to vertical side frames.



Step 6: Complete electrical connections between sections on vertical side frames.



Set Up Instructions

INFT-950L

Step 7: Insert center support pole between vertical side frames. Frame build completed.

Place frame on top of ground cloth before moving forward and installing graphics.

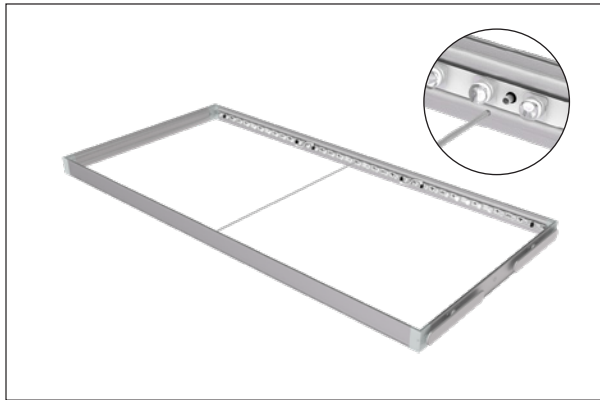

Step 8: To install a graphic start by inserting one eSEG™ Fabric Print into 4 corners of frame by pressing silicone into frame edge.

The fabric stretches on a diagonal and is easier to install by following Step 9.

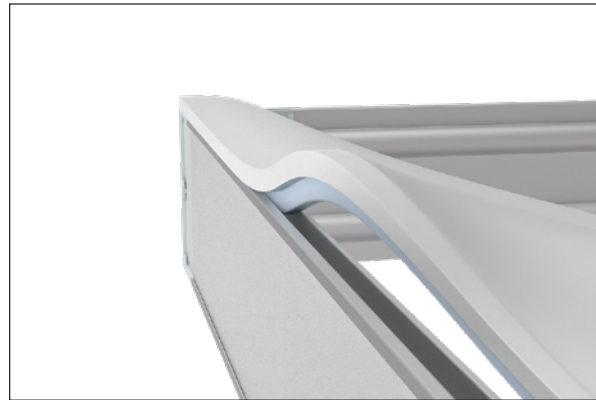

Step 9: Start in top corner (1) and then insert graphic into opposite bottom corner (2). Repeat on other side (3) and then (4). Then insert the graphic into center of each side and work back toward the corners.

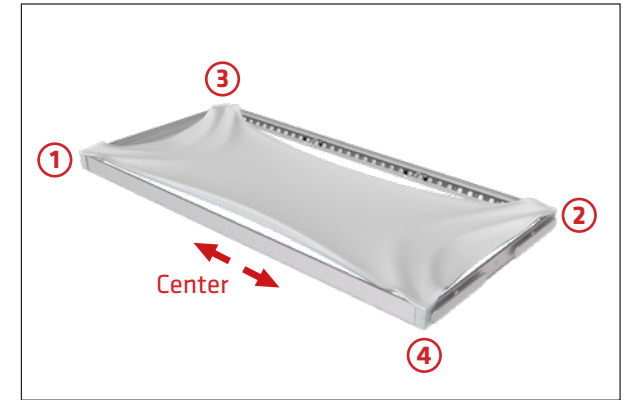

Step 10: Repeat for reverse side of frame.

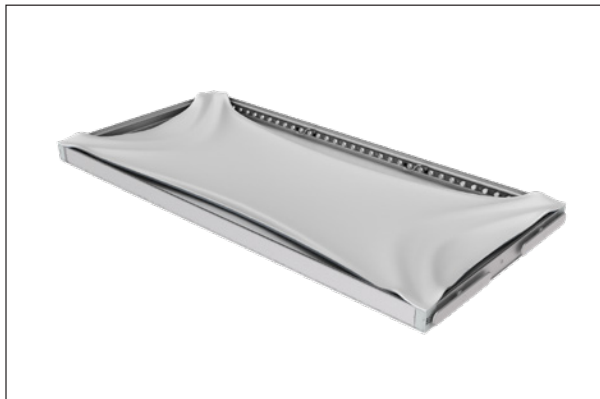

Step 11: Twist feet to open position.



Step 12: Plug power supply into bottom of frame and stand in upright position.



Set Up Instructions

INFT-950L

OPTIONAL: Unroll frame covers and slide them into the groove of the frame from top to bottom. For with one stand or on the outer two edges of multiple stands when connected together.



OPTIONAL: Connect frames together using wingnuts to create a continuous wall.

