

Frame Assembly

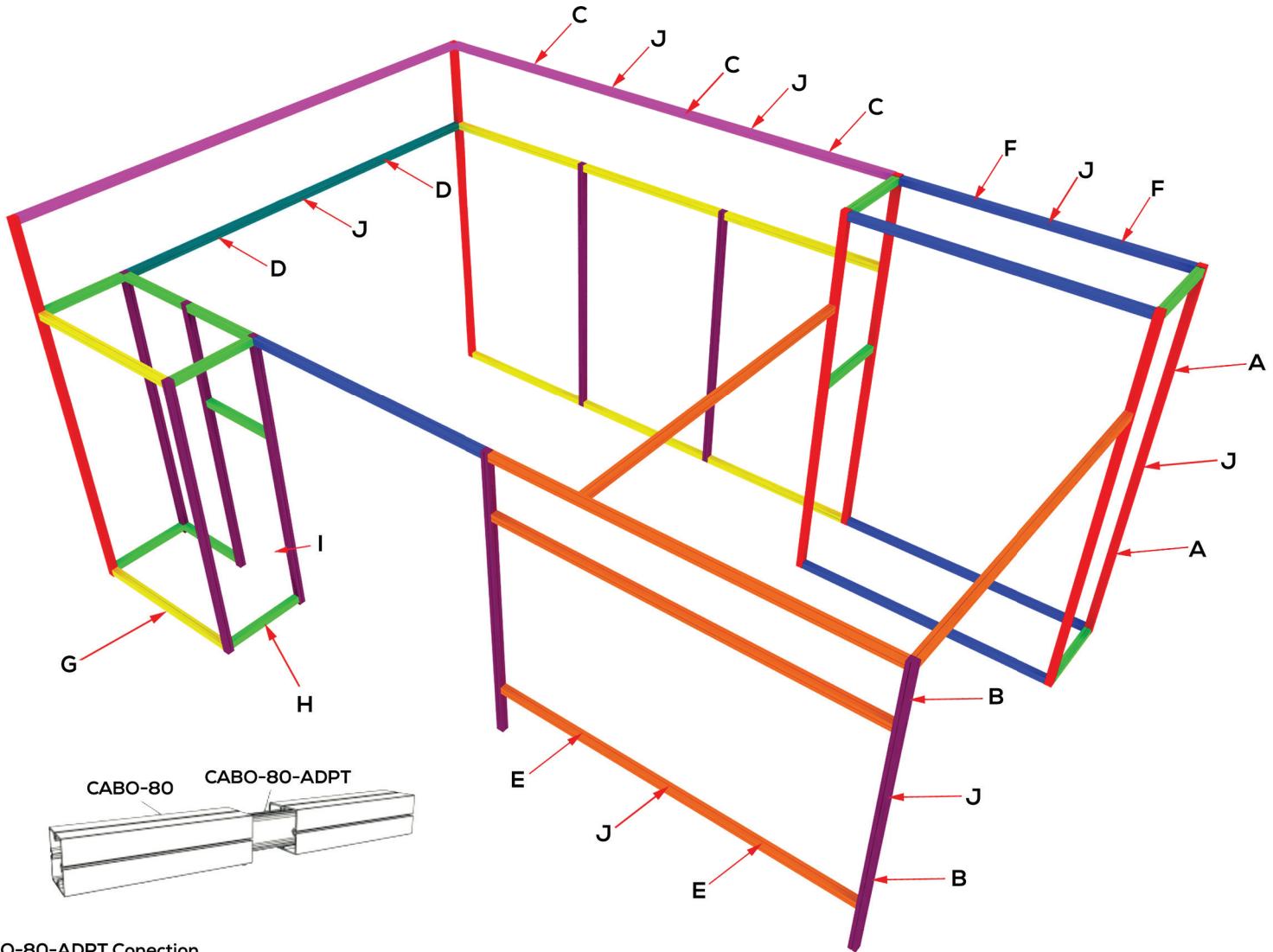

CABO-80-ADPT Connection

1. Insert CABO-80-ADPT into one CABO-80 profile
2. Slide opposing CABO-80 profile onto CABO-80-ADPT
3. Tighten screws on CABO-80-ADPT to secure profiles in place

REF	SKU	QTY	LENGTH IN
A	CABO-80	12	86.1"
B	CABO-80	16	66.65"
C	CABO-80	6	76.9"
D	CABO-80	2	95.85"
E	CABO-80	10	76.4"
F	CABO-80	10	56.9"
G	CABO-80	8	74.8"
H	CABO-80	12	35.8"
I	CABO-DOOR	2	n/a
J	CABO-80-ADPT	28	n/a

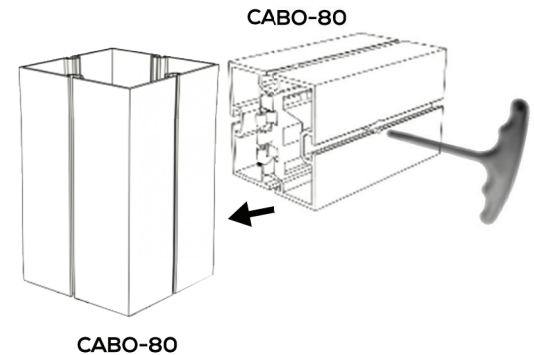

CABO 80 Profile Connection

1. Line up lock with system groove on vertical profile
2. Insert teeth of lock into groove
3. Use torx tool to tighten lock (turn clockwise to tighten)

SEG Attachments

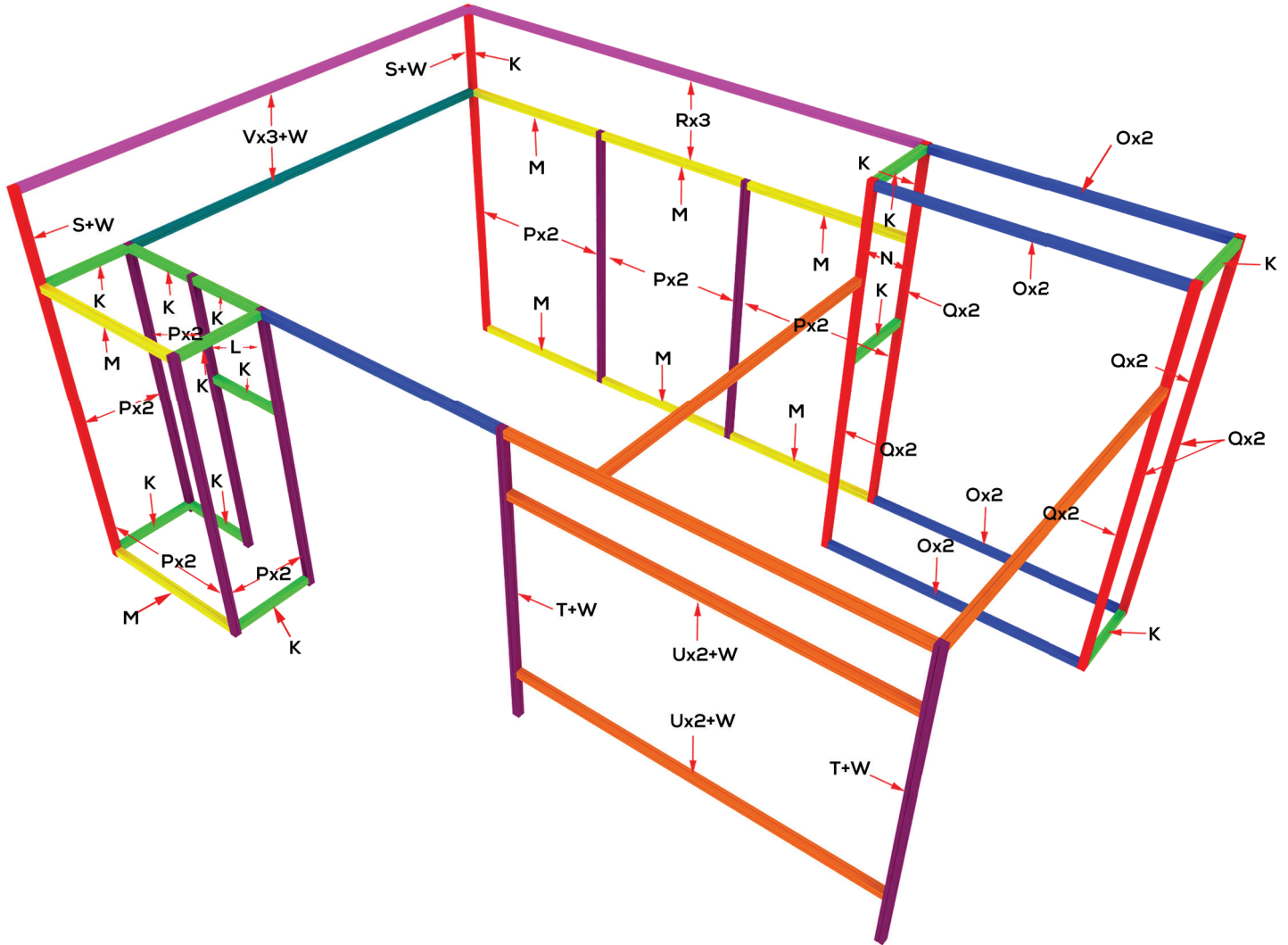

REF	SKU	QTY	LENGTH IN
K	CABO-SEG-PLASTIC	14	35.7"
L	CABO-SEG-PLASTIC	2	48.1"
M	CABO-SEG-PLASTIC	8	74.7"
N	CABO-SEG-PLASTIC	2	87.1"
O	CABO-SEG-PLASTIC	8	56.85"
P	CABO-SEG-PLASTIC	28	63.45"
Q	CABO-SEG-PLASTIC	12	82.95"
R	CABO-SEG-PLASTIC	6	76.9"
S	CABO-80-SEG	2	35.7"
T	CABO-80-SEG	2	70.8"
U	CABO-80-SEG	4	76.35"
V	CABO-80-SEG	6	76.9"
W	CABO-HHS	61	n/a

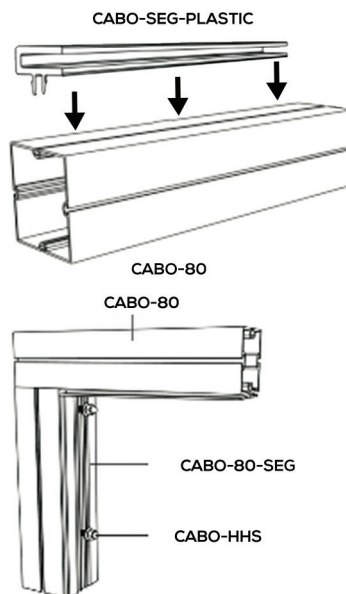

CABO-SEG-PLASTIC Installation
 1. Line up clip of CABO-SEG-PLASTIC with system groove of profile
 2. Press CABO-SEG-PLASTIC down to lock into place.

CABO-80-SEG Installation
 1. Unscrew CABO-HHS and feed through holes on CABO-80-SEG
 2. Line up CABO-HHS with system groove on profile CABO-80-SEG will attach to
 3. Tighten CABO-HHS clockwise to secure